

5.50 Gross Torque 158 CC

Bore 2.56 in. (65.1 mm)
Stroke 1.88 in. (47.7 mm)
Oil Capacity 18-20 fl. oz. (0.53 - 0.59 L)



Features:

- Kool Bore™ Aluminum alloy bore for cooler operation
- Prime 'N Pull Easy Starting System™ pumps the right amount of gas to carburetor for easy one-pull starts
- Maintenance-free Magnetron® electronic ignition for quick, dependable starts
- Mechanical compression release for smooth, quick starting
- Lube-Power™ gear-driven lubrication system bathes all internal engine parts with oil all the time
- Reusable foam element air cleaner protects engine from dirt for long life
- Large rewind starter reduces pulling effort for easy starts
- Mechanical torque control for additional power

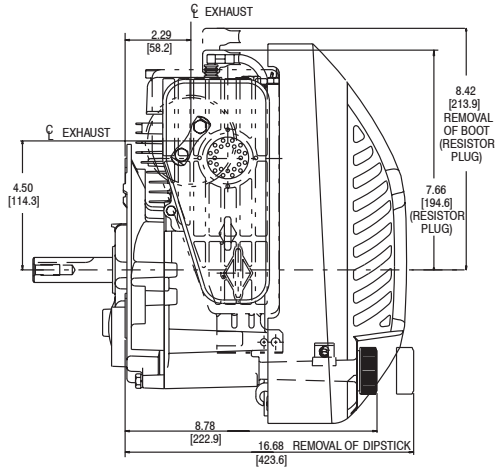
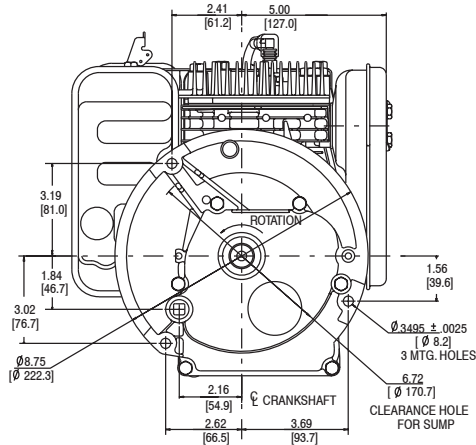
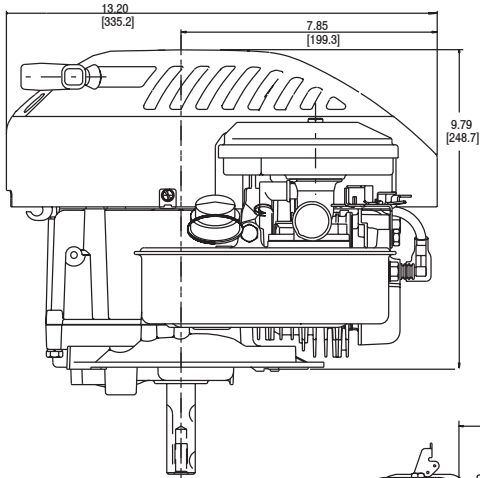

Model Type	Shipping Weight	Crankshaft	Crankshaft (P.T.O.) Extension	Dimension	Starter Position	Ext. Starter Rope	Governor	Controls	Primer Carburetor	Heavy Flywheel	Fuel Tank (Quarts)	Top Governor Speed	Notes
10T802													
0004		692989	Tapped 3/8-24, WK, and 3/16 Keyway, 7/8" dia.	1-13/16(b)	6		M	MF/R	X	X	1	3600	
0015	25	691472	Tapped 3/8-24, 2 WK, and 3/16 Keyway, 7/8" dia.	3-5/32(b)	6	X	M	MF/R	X		1	3200	◆
0016	25	691471	Tapped 3/8-24, 2 WK, and 3/16 Keyway, 7/8" dia.	2-7/16(b)	6	X	M	MF/R	X		1	3200	◆
0018	24	692989	Tapped 3/8-24, WK, and 3/16 Keyway, 7/8" dia.	1-13/16(b)	6	X	M	MF/R	X		1	3200	◆
10T812													
0005	29	692989	Tapped 3/8-24, WK, and 3/16 Keyway, 7/8" dia.	1-13/16(b)	6	X	M	MF/R	X	X	1	3600	

◆ The features on this engine are designed to meet Section 1205.5 of the Consumer Product Safety Commission Safety Standards.