

8.50 Gross Torque 190 CC

Bore 2.69 in. (68.3 mm)
Stroke 2.04 in. (51.8 mm)
Oil Capacity 18-20 fl. oz. (0.54 - 0.59 L)

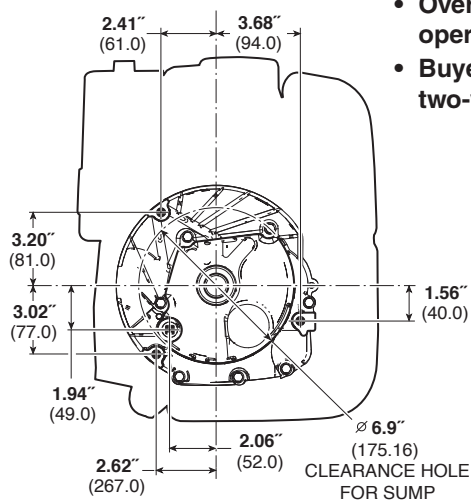
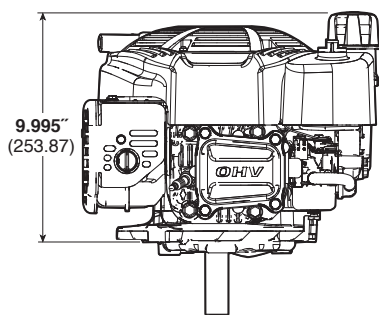
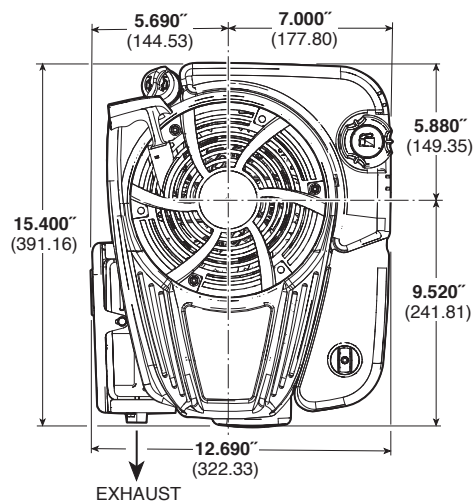

Features:

- Dura-Bore™ cast iron cylinder sleeve for extended life
- ReadyStart® provides easy no prime/ no choke starting
- Certified to CARB Tier III and meets EPA 2012 Phase 3 Standards
- Large rewind starter reduces pulling effort for easy starting
- Maintenance-free Magnatron® electronic ignition for quick, dependable starts
- Mechanical torque control for additional power
- Composite camshaft for quieter operation
- Commercial grade air cleaner with dual seals for longer engine life
- Large tube-outlet muffler reduces noise levels
- Overhead valve design (OHV) for cooler operation and longer valve life
- Buyer protection package provides two-year consumer engine warranty

Model Type	Shipping Weight	Crankshaft	Crankshaft (P.T.O.) Extension	Dimension	Starter Position	Ext. Starter Rope	Governor	Controls	5 Position Choke	Ready Start	Heavy Flywheel	Oil Pump w/Filter	Fuel Tank (Quarts)	Top Governor Speed	Notes
121Q02															
0003		796469	Tapped 3/8-24, 2 WK & Keyway, 7/8" dia.	3-5/32(b)	5:30	X	M	R	X				1.6	3600	
0015	29	796469	Tapped 3/8-24, 2 WK & Keyway, 7/8" dia.	3-5/32(b)	5:30	X	M	R/MF		X			1.6	3100	▼
0025	30	796468	Tapped 3/8-24, 2 WK & Keyway, 25 mm dia.	3-5/32(b)	5:30	X	M	R/MF		X			1.6	3100	▼
121Q07															
0060	33	796469	Tapped 3/8-24, 2 WK & Keyway, 7/8" dia.	3-5/32(b)	5:30	X	M	R/MF		X			1.6	3100	▼■
0062	33	796468	Tapped 3/8-24, 2 WK & Keyway, 25 mm dia.	3-5/32(b)	5:30	X	M	R/MF		X			1.6	3100	▼■
121Q12															
0008		796469	Tapped 3/8-24, 2 WK & Keyway, 7/8" dia.	3-5/32(b)	5:30	X	M	R/MF		X			1.6	3600	
121Q72															
0020	31	796469	Tapped 3/8-24, 2 WK & Keyway, 7/8" dia.	3-5/32(b)	5:30	X	M	R/MF		X		X	1.6	3100	▼

▼ The features on this engine are designed to meet Section 1205.5 of the Consumer Product Safety Commission Safety Standards.
■ Engine equipped with 12 Volt Gear Drive Starter and .5 Amp DC Alternator.