

9.00 Gross Torque 205 CC

Bore 2.69 in. (68.3 mm)
Stroke 2.2 in. (55.9 mm)
Oil Capacity 18-20 fl. oz. (0.53 - 0.59 L)



Features:

- Dura-Bore™ cast iron cylinder sleeve for extended life
- Float carburetor for consistent easy starting
- Maintenance-free Magnetron® electronic ignition for quick, dependable starts
- Dual-Clean™ air cleaner pleated paper filter with a foam pre-cleaner ensures maximum protection for extended engine life
- Overhead valve design (OHV) for cooler operation and longer valve life
- Buyer protection package provides two-year consumer engine warranty

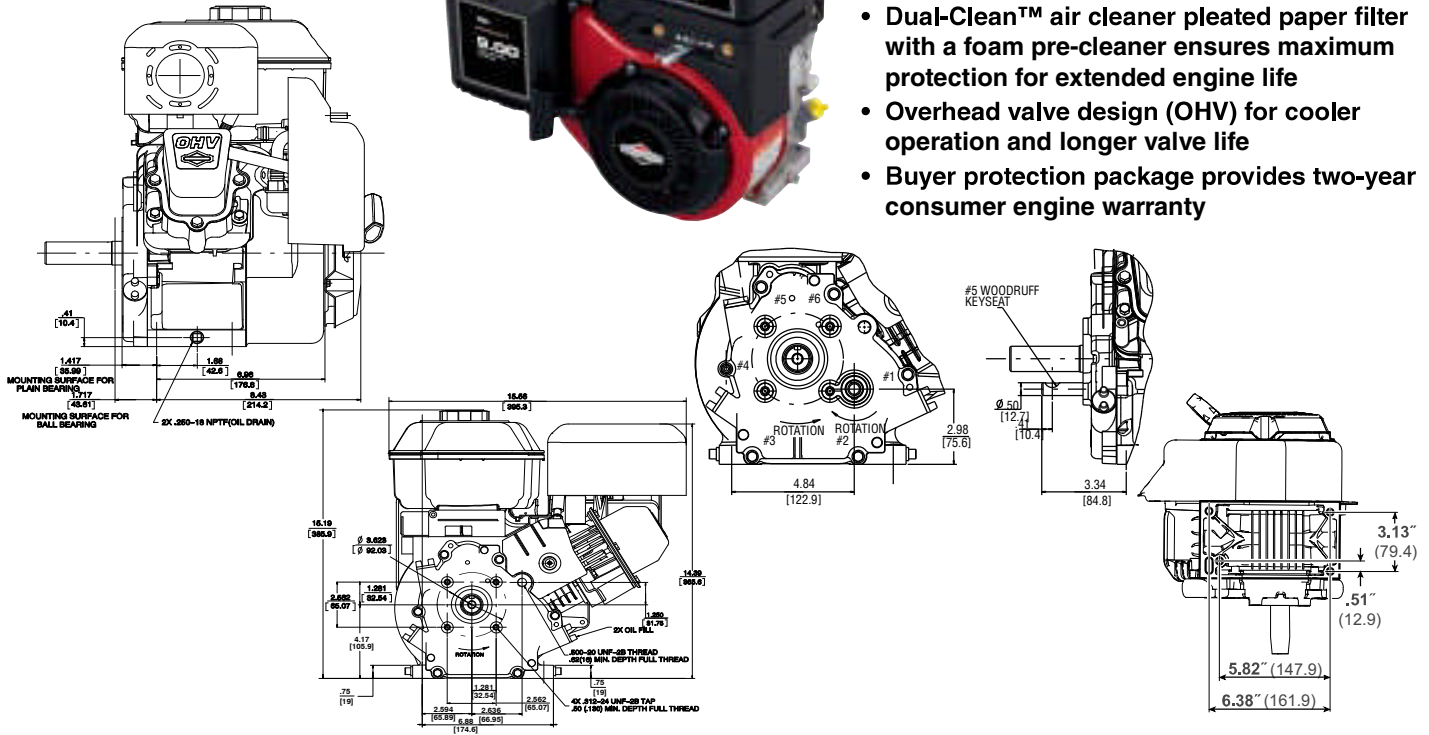

Model Type	Shipping Weight	Crankshaft	Crankshaft (P.T.O.) Extension	Dimension	Starter Position	Oil Filler & Drain	Governor	Controls	Manual Choke	Fuel Tank (Quarts)	Remote Stop Switch	Flange Mtg.	Top Governor Speed	Notes
122002														
0520	39	699445	3/4" dia., Keyway, tapped 5/16-24	2-5/16(a)	10:30	T	M	R/AG/MF	X	3	X		3400	
122012														
0522	43	699449	3/4" dia., Keyway, tapped 3/8-24	1-29/64(c)	10:30	T	M	R/AG/MF	X	3	X	X	3400	
0523	39	699445	3/4" dia., Keyway, tapped 5/16-24	2-5/16(a)	10:30	T	M	R/AG/MF	X	3	X	X	3800	
0526	39	699447	Tapered, tapped 5/16-24	2-13/16(c)	10:30	T	M	FC	X	3	X	X	3750	
0528	39	699452	Tapered, tapped 3/8-24	2-23/32(c)	10:30	T	M	R/AG/MF	X	3	X	X	3600	
0560	35	797075	1" dia., Keyway, tapped 3/8-24	2-7/8(c)	10:30	T	M	R/AG/MF	X	3	X	X	3800	
122032														
0533	40	699442	Tapered, tapped 5/16-24	2-13/16(c)	10:30	T	M	AG	X	3		X	3750	•
0535	38	699441	Threaded 5/8-18	2-27/64(c)	10:30	T	M	R/AG/MF	X	3	X	X	4000	•
0536	39	699443	3/4" dia., Keyway, tapped 5/16-24	2-27/64(c)	10:30	T	M	R/AG/MF	X	3	X	X	3600	•
122037														
0550	40	699443	3/4" dia., Keyway, tapped 5/16-24	2-27/64(c)	10:30	T	M	R/AG/MF	X	3	X	X	3600	• □
122052														
0549	42	699444	6 to 1 Gear reduction CCW rotation, Gear Shaft 3/4" dia., Keyway	2(a)	10:30	T	M	R/AG/MF	X	3	X	X	3600	
122092														
0570	37	699445	3/4" dia., Keyway, tapped 5/16-24, Aux P.T.O., 1/2" dia	2-15/16(a)	10:30	T	M	R/AG/MF	X	3	X	X	3600	
0571	38	699451	1" dia., Keyway, tapped 3/8-24, Aux P.T.O., 1/2" dia	2-7/8(c)	10:30	T	M	R/AG/MF	X	3		X	3800	

• Ball bearing PTO and DU magneto side □ Engine equipped with 12 Volt Gear Drive Starter and 1.5 AMP DC Alternator.