

11.50 Gross Torque 250 CC

Bore 2.97 in. (75.45 mm)

Stroke 2.20 in. (55.90 mm)

Oil Capacity 26-28 fl. oz. (0.77 - 0.83 L)



Features:

- Kool Bore™ Aluminum alloy bore for cooler operation
- Float carburetor for consistent easy starting
- Maintenance-free Magnetron® electronic ignition for quick, dependable starts
- Overhead valve design (OHV) for cooler operation and longer valve life
- Dual-Clean™ air cleaner pleated paper filter with a foam pre-cleaner ensures maximum protection for extended engine life
- Buyer protection package provides two-year consumer engine warranty

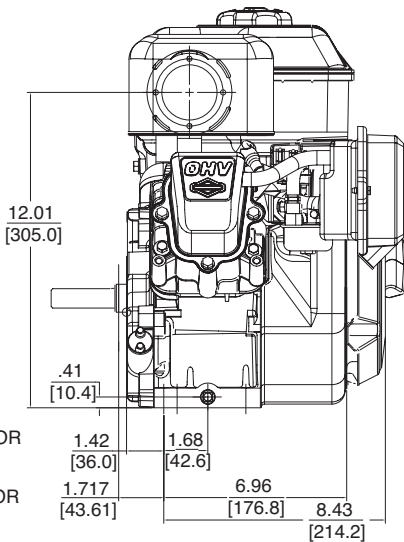

MOUNTING SURFACE FOR BALL BEARING

MOUNTING SURFACE FOR PLAIN BEARING

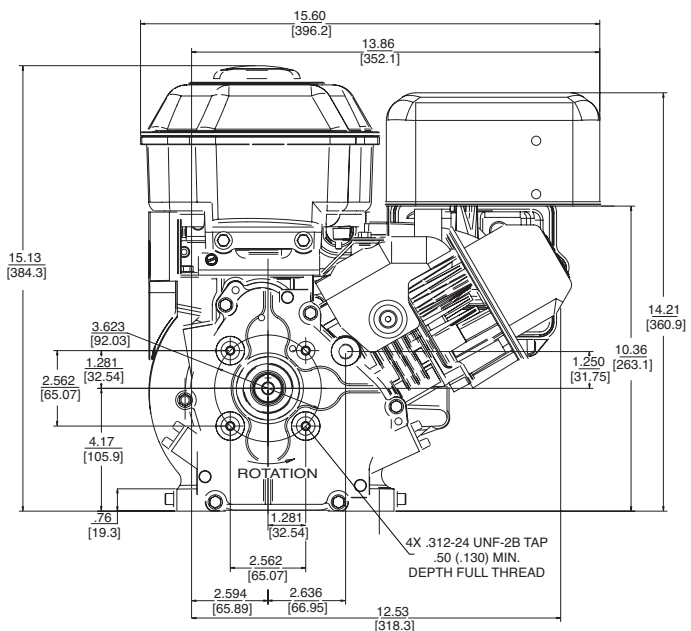

Model Type	Shipping Weight	Crankshaft	Crankshaft (P.T.O.) Extension	Dimension	Starter Position	Oil Filler & Drain	Governor	Controls	Manual Choke	Fuel Tank (Quarts)	Remote Stop Switch	Flange Mtg.	Top Governor Speed	Notes
150212														
0523		792208	3/4" dia., Keyway, tapped 3/8-24	2-5/16(a)	10:30	D	M	R/AG/MF	X	3	X	X	3800	
0526		793199	Tapered, tapped 5/16-24	2-13/16(c)	1:30	D	M	FC	X	3		X	3750	
0560	40	792977	1" dia., Keyway, tapped 3/8-24	2-7/8(c)	10:30	D	M	R/AG/MF	X	3	X	X	3800	
150232														
2536		699443	3/4" dia., Keyway, tapped 5/16-24	2-27/64(c)	10:30	T	M	R/AG/MF	X	3		X	3600	•
150292														
0571		792977	1" dia., Keyway, tapped 3/8-24	2-7/8(c)	10:30	D	M	R/AG/MF	X	3		X	3800	

• Ball bearing PTO