

# Vanguard™ 10.0 Gross HP 305 CC

Bore 3.12 in. (79.25 mm)  
Stroke 2.44 in. (61.98 mm)  
Oil Capacity 28 fl. oz. (.83 L)



## Features:

- Dura-Bore™ cast iron cylinder sleeve for extended life
- Float carburetor for consistent easy starting
- Maintenance-free Magnetron® electronic ignition for quick, dependable starts
- Dual-Clean™ air cleaner pleated paper filter with a foam pre-cleaner ensures maximum protection for extended engine life
- Oil Gard low oil engine shutdown device
- Overhead valve design (OHV) for cooler operation and longer valve life
- Buyer protection package provides three-year consumer engine warranty

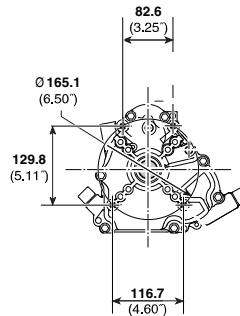
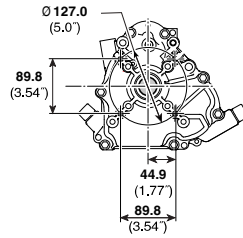
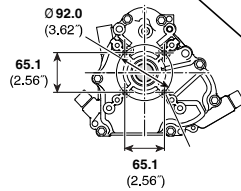
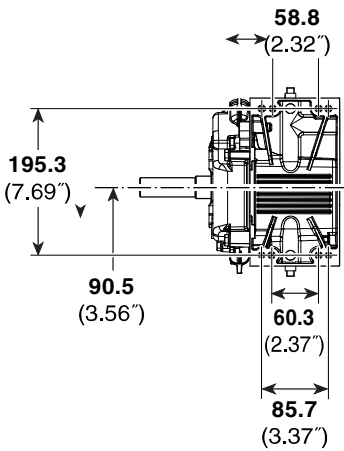
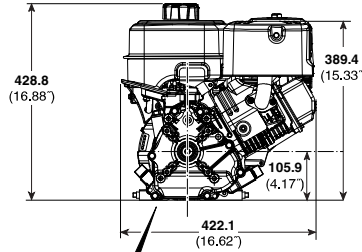
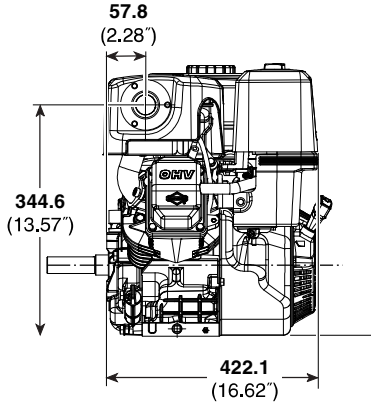

Model Type	Shipping Weight	Crankshaft	Crankshaft (P.T.O.) Extension	Dimension	Starter Position Bolt-On/Changeable	Governor	Controls	Flange Mtg.	Manual Choke	Transport Guard™ Fuel/Ignition Shut-off	Oil Gard	Fuel Tank (Liters)	Top Governor Speed	Notes
19L232														
0036		590368	1" dia., Keyway, tapped 3/8-24	2-29/32(c)	10:30	M	AG/R/MF	X	X	X	X	3.6	3600	•
0037		796957	1" dia., Keyway, tapped 7/16-20	3-21/32(c)	10:30	M	AG/R/MF	X	X	X	X	3.6	3600	•
19L237														
0042		796957	1" dia., Keyway, tapped 7/16-20	3-21/32(c)	10:30	M	AG/R/MF	X	X	X	X	3.6	3600	•◆
19L252														
0049		794721	6 to 1 gear reduction ccw rotation gear shaft, 1" dia Keyway	3-1/8(a)	10:30	M	AG/R/MF		X	X	X	3.6	3600	☞

◆ Engine equipped with 12 Volt Gear Drive Starter and 10 Amp DC Alternator with Starter Panel Assembly.

☞ Engine equipped with 12 Volt Gear Drive Starter and 3 Amp DC Alternator. ☞ Ball Bearing Magneto Side • Ball bearing PTO and Magneto Side