

14.50 GROSS TORQUE*

306 CC

Bore 3.22 in. (81.80 mm)
Stroke 2.28 in. (57.90 mm)
Oil Capacity 37 fl. oz. (1.09 L)

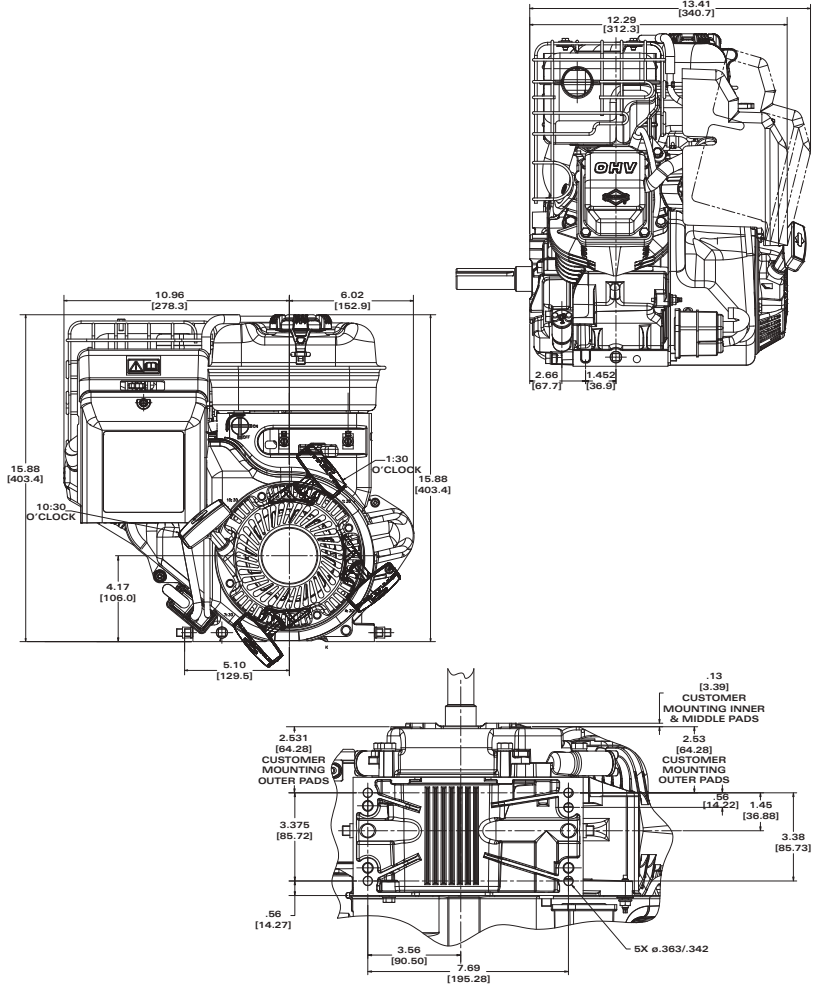

FEATURES:

- Dura-Bore™ cast iron cylinder sleeve for extended life
- Dual-Clean™ air cleaner pleated paper filter with a foam pre-cleaner ensures maximum protection for extended engine life
- Overhead valve design (OHV) for cooler operation and longer valve life
- Duel Ball Bearing
- Mechanical Governor
- Buyer protection package provides two-year limited consumer engine warranty****

MTT	Crankshaft #	P.T.O. Diameter	Drilled & Tapped	Keyway	Length	Starter Position	Controls	Manual Choke	Flange Mtg.	Accessory Mtg. Boss	Ground Wire Terminal	Rockler Stop Switch	Key Stop Switch	Oil Guard	Fuel Tank (Quarts)	Top Governor Speed	Notes
19N132																	
0035-F1	593084	1 in.	7/16-20	1/4-Str.	3-31/64	10:00	MF/R	X			X	X	X	X	3.2	3750	11
0051-F1	593662	3/4 in.	3/8-24	3/16-Str.	2-1/2	10:00	MF/R	X			X	X			3.2	3750	11
0055-F1	593691	1 in.	3/8-24	1/4-Str.	2-49/64	10:00	MF/R	X			X	X		X	3.2	3750	11
19N137																	
0052-F1	593084	1 in.	7/16-20	1/4-Str.	3-31/64	10:00	MF/R	X			X		X	X	3.2	3600	5,11
0053-F1	593662	3/4 in.	3/8-24	3/16-Str.	2-1/2	10:00	MF/R	X			X		X		3.2	3600	5,11

*All power levels are stated gross torque at 2600 RPM per SAE J1940 as rated by Briggs & Stratton.

(5) Engine equipped with 12 Volt Gear Drive Starter and 9 Amp DC Alternator

(11) PTO Ball Bearing

Engines in bold type have promotional pricing