

8 HP INTEK™ *VE* Model Series 202400

Displacement 18.6 cu. in. (305 cc)
Bore 3.12 in. (79 mm)
Stroke 2.43 in. (61 mm)
Oil Capacity 28 fl. oz. (0.82 l)



Features:

- Dura-Bore™ cast iron cylinder sleeve for extended life
- Maintenance-free Magnetron® electronic ignition for quick, dependable starts
- Dual-Clean™ air cleaner pleated paper filter with a foam pre-cleaner ensures maximum protection for extended engine life
- Overhead valve design (OHV) for cooler operation and longer valve life
- Buyer protection package provides two-year consumer engine warranty

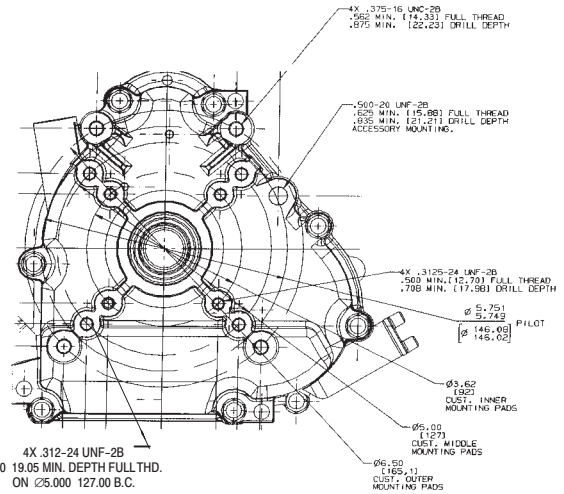
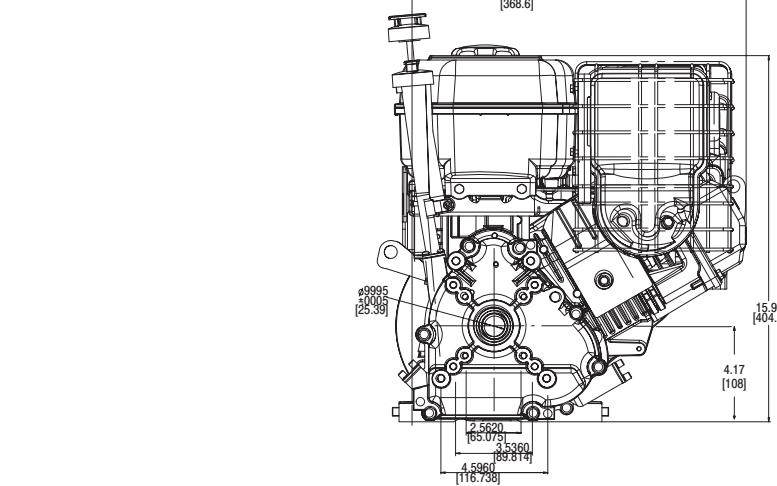
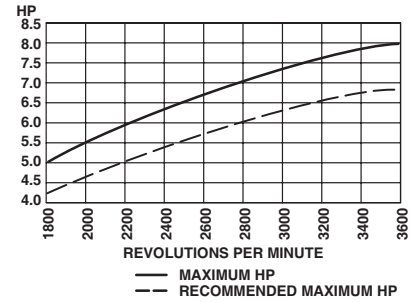
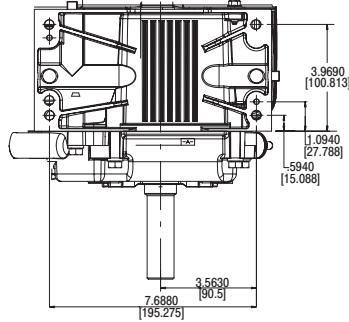
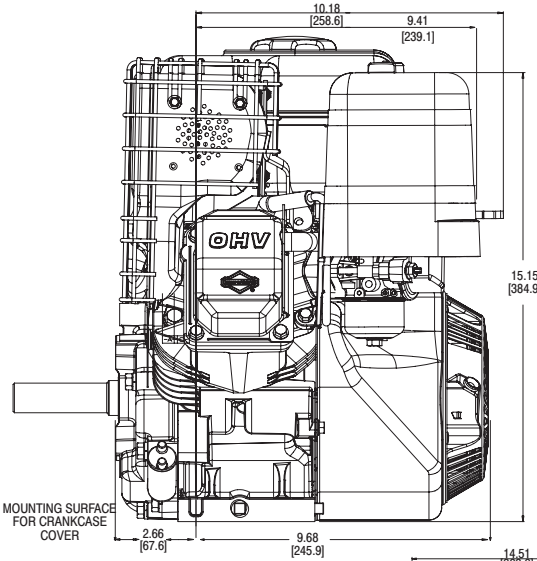

To make the center line of crankshaft the same as 190000 Model Series, order 695154 spacer kit.

Model Type	Shipping Weight		Crankshaft	Crankshaft (P.T.O.) Extension	Dimension	Starter Position Bolt-On/Changeable	Governor	Controls	Flange Mtg.	Manual Choke	Remote Stop Switch	Fuel Tank (Quarts)	Top Governor Speed	Notes
	Weight	Height												
202432														
0035	51	695818	Threaded 1-14, 1" tapped length		3-21/32(c)	10:30	M	AG/R/MF	X	X	X	4	3600	•
0036	52	695369	1" dia., Keyway, tapped 3/8-24		2-29/32(c)	10:30	M	AG/R/MF	X	X	X	4	3600	•
0063	65	696412	3/4" dia., 3/16 Keyway, tapped 3/8-24		2-21/32(c)	10:30	M	AG/R/MF	X	X	X	4	3600	•
202437														
0033	69	696412	3/4" dia., 3/16 Keyway, tapped 3/8-24		2-21/32(c)	10:30	M	AG/R/MF	X	X	X	4	3600	•■
0041	60	695369	1" dia., Keyway, tapped 3/8-24		2-29/32(c)	10:30	M	AG/R/MF	X	X	X	4	3600	•◆
202452														
0049	65	695817	6 to 1 gear reduction ccw rotation gear shaft, 1" dia Keyway		2-29/32(a)	10:30	M	AG/R/MF	X	X	X	4	3600	

• Ball bearing PTO ◆ Engine equipped with 12 Volt Gear Drive Starter and 10 Amp DC Alternator with Starter Panel Assembly.
■ Engine equipped with 12 Volt Gear Drive Starter and 3 Amp DC Alternator