

15.50 Gross Torque 342 CC

Bore 3.30 in. (83.8 mm)

Stroke 2.44 in. (61.9 mm)

Oil Capacity 26-28 fl. oz. (0.77 - 0.83 L)



Features:

- **Kool Bore™** Aluminum alloy bore for cooler operation
- **Maintenance-free Magnetron®** electronic ignition for quick, dependable starts
- **Overhead valve design (OHV)** for cooler operation and longer valve life
- **Maxi-Clean™** automotive-type pleated paper air filter provides superior protection for long engine life
- **Buyer protection package** provides two-year consumer engine warranty

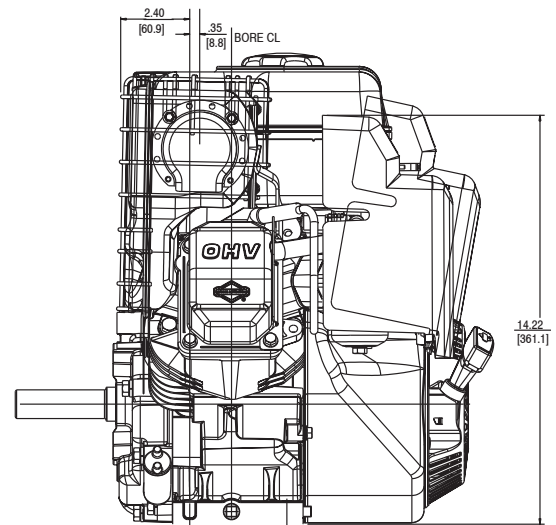
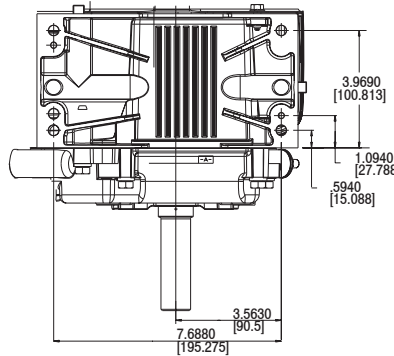
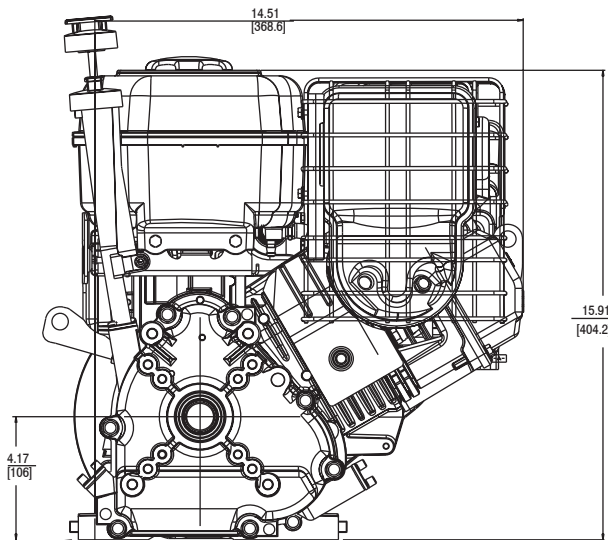

To make the center line of crankshaft the same as 190000 and 250000 Model Series, order 695154 spacer kit.

Model Type	Shipping Weight	Crankshaft	Crankshaft (P.T.O.) Extension	Dimension	Starter Position Bolt-On\Changeable	Governor	Controls	Flange Mtg.	Manual Choke	Remote Stop Switch	Fuel Tank (Quarts)	Top Governor Speed	Notes
210412													
0570	58	694678	Tapered, Tapped 5/16-24	4-11/32(c)	1:30	M	FC	X	X	X	*	3750	
210432													
0535	62	695818	Threaded 1-14, 1" Thread Length	3-21/32(c)	10:30	M	MF	X	X	X	4	3600	•
0536	63	695462	1" dia., Keyway, tapped 7/16-20	3-21/32(c)	10:30	M	AG/R/MF	X	X	X	4	3600	•
0546	61	695369	1" dia., Keyway, tapped 3/8-24	2-29/32(c)	10:30	M	FC	X	X	X	4	3600	•

• Ball bearing PTO * Fuel Tank Omitted