

INTEK™ 10.5 Gross HP

344 CC

Bore 3.44 in. (87.4 mm)

Stroke 2.27 in. (57.7 mm)

Oil Capacity 48 fl. oz. (1.4 L)



Features:

- Dura-Bore™ cast iron cylinder sleeve for extended life
- Float carburetor for consistent easy starting
- Maintenance-free Magnetron® electronic ignition for quick, dependable starts
- Dual-Clean™ air cleaner pleated paper filter with a foam pre-cleaner ensures maximum protection for extended engine life
- Overhead valve design (OHV) for cooler operation and longer valve life
- Patented linear balancing system provides smoother performance
- Buyer protection package provides two-year consumer engine warranty

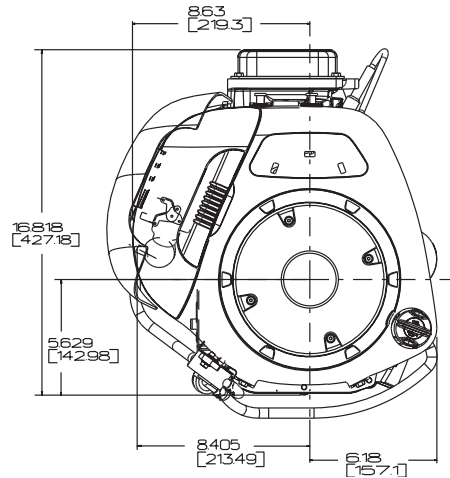
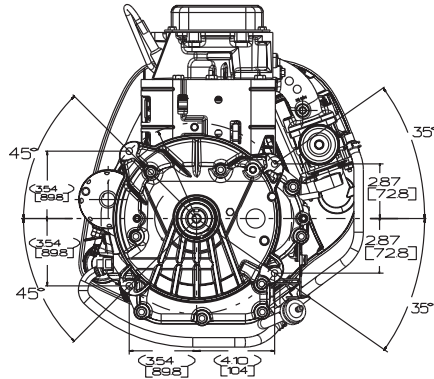
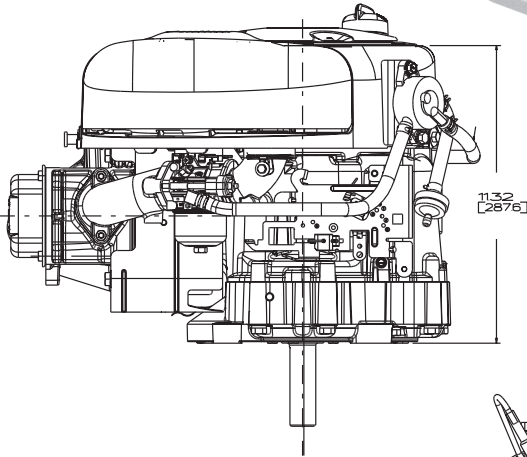

For Fuel Tank Dimensions, see page 57

Model Type	Shipping Weight	Crankshaft	Crankshaft (P.T.O.) Extension	Dimension	Starter Position Bolt-On/Changeable	Ext. Oil Fill & Dipstick	Governor	Controls	Pulse Fuel Pump	Oil Pump with Filter	Choke-A-Matic®	Ground Wire Terminal	Fuel Tank (Quarts)	Top Governor Speed	Notes
215902															
0015	70	697390	Tapped 7/16-20, Keyway, 1" dia.	3-5/32(b)	9	X	M	R			X	X	■	3400	
0020	71	697390	Tapped 7/16-20, Keyway, 1" dia.	3-5/32(b)	9	X	M	R	X		X	X	3	3400	
215907															
0025	76	697390	Tapped 7/16-20, Keyway, 1" dia.	3-5/32(b)	9	X	M	R			X	X	■	3600	▼
0026	77	697390	Tapped 7/16-20, Keyway, 1" dia.	3-5/32(b)		X	M	R			X	X	■	3600	▼
0028	79	697390	Tapped 7/16-20, Keyway, 1" dia.	3-5/32(b)	9	X	M	R	X		X	X	3	3600	▼

■ Fuel tank omitted. ▼ Engine equipped with 12 Volt Gear Drive Starter and Dual Circuit Alternator. (3 Amp DC - 14 Volts AC)