

# 18 HP VANGUARD™ Model Series 350700

Displacement 34.75 cu. in. (570 cc)

Bore 2.83 in. (72 mm)

Stroke 2.75 in. (70 mm)

Oil Capacity 48 fl. oz. (1.42 l)  
w/o Filter  
56 fl. oz. (1.66 l)  
w/Filter



COMMERCIAL POWER



## Features:

- Dura-Bore™ cast iron cylinder sleeve for extended life
- Dependable float feed type carburetor with integral fuel pump for remote mount fuel tank
- Maintenance-free Magnetron® electronic ignition for quick, dependable starts
- Dual-Clean™ air cleaner pleated paper filter with a foam pre-cleaner ensures maximum protection for extended engine life
- Full pressure lubrication with spin-on oil filter assures controlled lubrication for extended component life
- Overhead valve design (OHV) for cooler operation and longer valve life
- Buyer protection package provides two-year commercial engine warranty

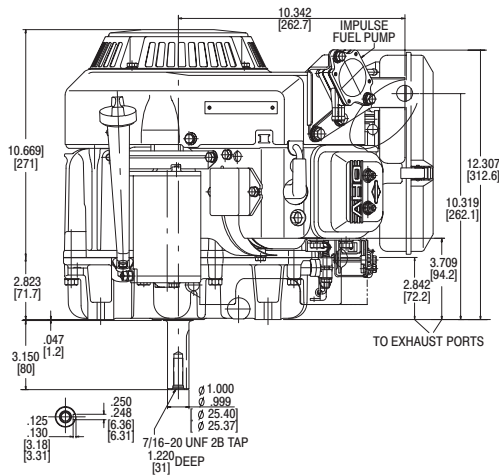
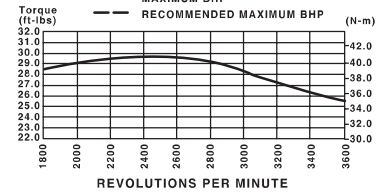
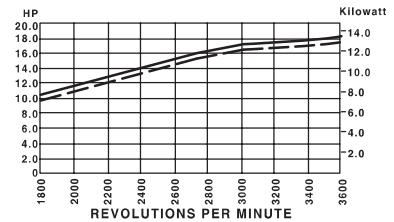
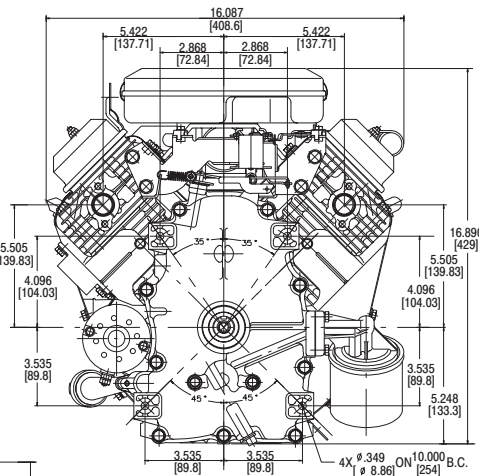
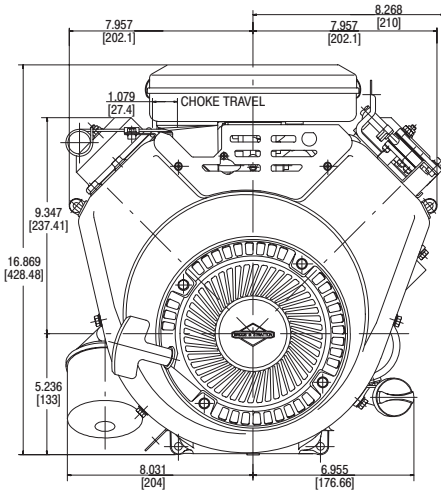

See Engine Accessories & Products Catalog Form MS-3880 for Exhaust Manifold and Muffler Options.

Model Type	Shipping Weight	Crankshaft	Crankshaft (P.T.O.) Extension	Dimension	Starter Position Bolt-On/Changeable	Governor	Controls	Exhaust System	Fuel Tank (Quarts)	Ground Wire Terminal	Ext. Oil Fill & Dipstick	Oil Pump w/Filter	Remote Choke	Top Governor Speed	Notes
350776	81	692172	Tapped 7/16-20, Keyway, 1" dia.	3-5/32(b)	9	M	R	• ■	X	X	X	X	X	3600	▼
350777	86	692172	Tapped 7/16-20, Keyway, 1" dia.	3-5/32(b)		M	R	• ■	X	X	X	X	X	3300	†

• Exhaust manifold and muffler omitted.  
▼ Engine equipped with 9 Amp DC Alternator

■ Fuel tank omitted.

† Engine equipped with 12 Volt Gear Drive Starter and 16 Amp DC Alternator.