

Vanguard™ 18.0 Gross HP 570 CC

Bore 2.83 in. (72 mm)
Stroke 2.75 in. (70 mm)
Oil Capacity: 48 fl. oz. (1.42 L)



FEATURES
COOLER/CLEANER
TECHNOLOGY



Features:

- Dura-Bore™ cast iron cylinder sleeve for extended life
- Float carburetor for consistent easy starting
- Maintenance-free Magnetron® electronic ignition for quick, dependable starts
- Dual-Clean™ air cleaner pleated paper filter with a foam pre-cleaner ensures maximum protection for extended engine life
- Full pressure lubrication with spin-on oil filter assures controlled lubrication for extended component life
- Overhead valve design (OHV) for cooler operation and longer valve life
- Buyer protection package provides two-year commercial engine warranty

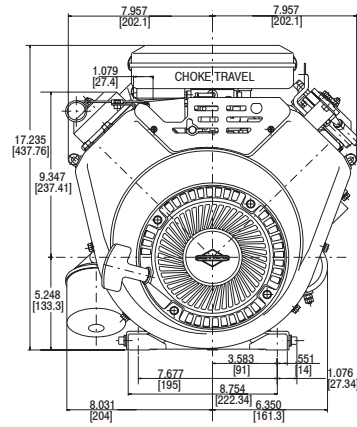
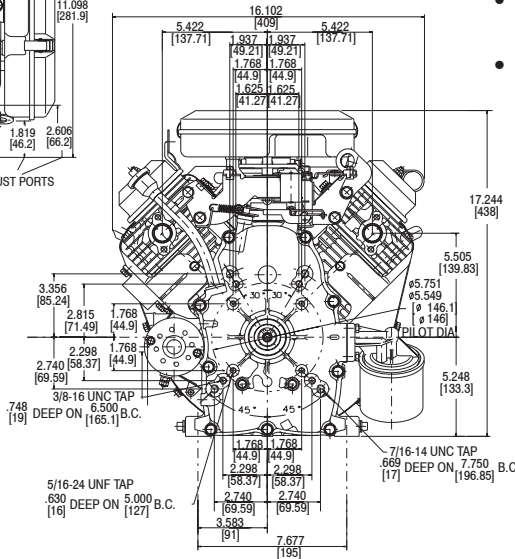
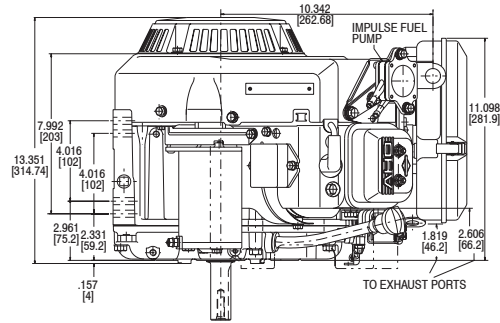

Model Type	Shipping Weight	Crankshaft	Crankshaft (P.T.O.) Extension	Dimension	Starter Position Bolt-On/Changeable	Oil Filler & Drain	Governor	Controls	Exhaust System	Fuel Tank (Quarts)	Pulse Fuel Pump	Flange Mtg.	Oil Pump w/Filter	Manual & Remotechoke	Top Governor Speed	Notes
356442																
0065	88	809842	1" dia., Keyway, tapped 3/8-24	2-29/32(c)	9	*	M	AG/R/MF	•	9		X	X	X	3600	
356447																
0005	89	809811	Tapered, tapped 5/16-24	3-51/64(c)	9	*	E	FC	•	■	X	X	X		3600	◆
0009	98	809842	1" dia., Keyway, tapped 3/8-24	2-29/32(c)	9	*	E	FC	•	9		X	X	X	3600	□
0066	102	809842	1" dia., Keyway, tapped 3/8-24	2-29/32(c)	9	*	M	AG/R/MF		9		X	X	X	3600	◆
0075	93	809842	1" dia., Keyway, tapped 3/8-24	2-29/32(c)	9	*	M	AG/R/MF	•	■	X	X	X	X	3600	◆
0077	89	809804	Threaded 1-14, 1" thread length	3-21/32(c)	9	*	M	AG/R/MF	•	■	X	X	X	X	3600	◆
0078	89	809811	Tapered, tapped 5/16-24	3-51/64(c)	9	*	M	AG	•	■	X	X	X		3750	◆
0079	89	809842	1" dia., Keyway, tapped 3/8-24	2-29/32(c)		*	M	AG/R/MF	•	■	X	X	X	X	3600	◆
0087	90	809832	1-1/8" dia., Keyway, tapped 7/16-20	4(c)	9	*	M	AG/R/MF	•	■	X	X	X	X	3600	◆
0096	96	809842	1" dia., Keyway, tapped 3/8-24	2-29/32(c)	9	*	M	AG/R/MF	•	9		X	X	X	3600	◆

* Oil fill and dipstick in cover; dual drain. See Engine Accessories Catalog MS-3880 for Exhaust Manifold and Muffler Options.

◆ Engine equipped with 12 Volt Gear Drive Starter and 16 Amp DC Alternator with Starter Panel Assembly.

□ Engine equipped with 12 Volt Gear Drive Starter and 20 Amp DC Alternator with Starter Panel. ■ Fuel tank omitted. • Exhaust manifold and muffler omitted.