

Vanguard™ 23.0 Gross HP 627 CC

Bore 2.97 in. (75.5 mm)
Stroke 2.76 in. (70 mm)
Oil Capacity 48 fl. oz. (1.4 L)



FEATURING
COOLER/CLEANER
TECHNOLOGY



Features:

- Dura-Bore™ cast iron cylinder sleeve for extended life
- Dependable float feed type carburetor with integral fuel pump for remote mount fuel tank
- Maintenance-free Magnatron® electronic ignition for quick, dependable starts
- Dual-Clean™ air cleaner pleated paper filter with a foam pre-cleaner ensures maximum protection for extended engine life
- Full pressure lubrication with oil cooler and spin-on oil filter assures controlled lubrication for extended component life
- Overhead valve design (OHV) for cooler operation and longer valve life
- Buyer protection package provides three-year commercial limited warranty

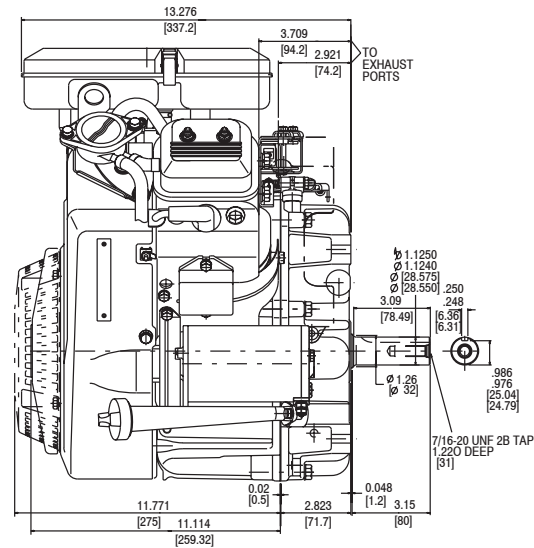
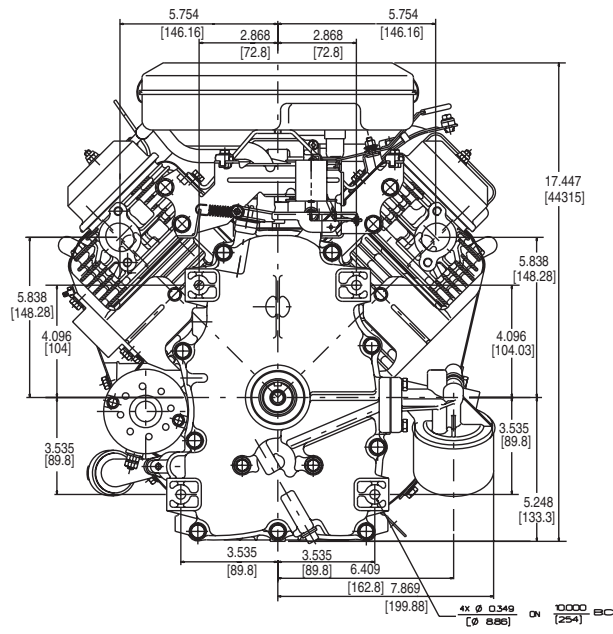

Model Type	Shipping Weight	Crankshaft	Crankshaft (P.T.O.) Extension	Dimension	Starter Position Bolt-On/Changeable	Governor	Controls	Exhaust System	Fuel Tank (Quarts)	Ground Wire Terminal	Ext. Oil Fill & Dipstick	Oil Pump w/Filter	Remote Choke	Top Governor Speed	Notes
386777															
0024	96	809830	Tapped 7/16-20, Keyway, 1-1/8" dia.	3-5/32(b)		M	R	•	■	X	X	X	X	3600	†
0025	93	809840	Tapped 7/16-20, Keyway, 1-1/8" dia.	4(b)		M	R	•	■	X	X	X	X	3600	†
0036	93	809809	Tapped 7/16-20, Keyway, 1" dia.	3-5/32(b)		M	R	•	■	X	X	X	X	3300	†

• Exhaust manifold and muffler omitted. See Briggs & Stratton Master Parts Catalog MS-4185 for Exhaust Manifold and Muffler Options.
■ Fuel tank omitted. † Engine equipped with 12 Volt Gear Drive Starter and 16 Amp DC Alternator.