

# INTEK™ 23.0 Gross HP 724 CC

Bore 3.12 in. (79.2 mm)  
Stroke 2.89 in. (73.4 mm)  
Oil Capacity 64 fl. oz. (1.9 L)



## Features:

- Dura-Bore™ cast iron cylinder sleeve for extended life
- Dependable float feed type carburetor with integral fuel pump for remote mount fuel tank
- Maintenance-free Magnetron® electronic ignition for quick, dependable starts
- Dual-Clean™ air cleaner pleated paper filter with a foam pre-cleaner ensures maximum protection for extended engine life
- Full pressure lubrication with spin-on oil filter assures controlled lubrication for extended component life
- Overhead valve design (OHV) for cooler operation and longer valve life
- Buyer protection package provides two-year consumer engine warranty

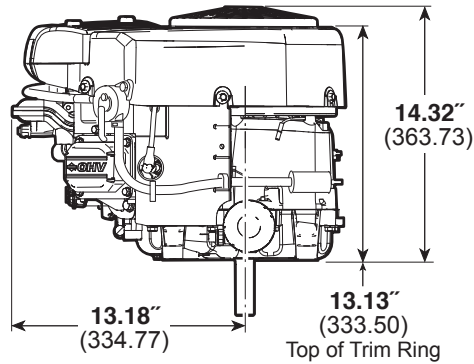
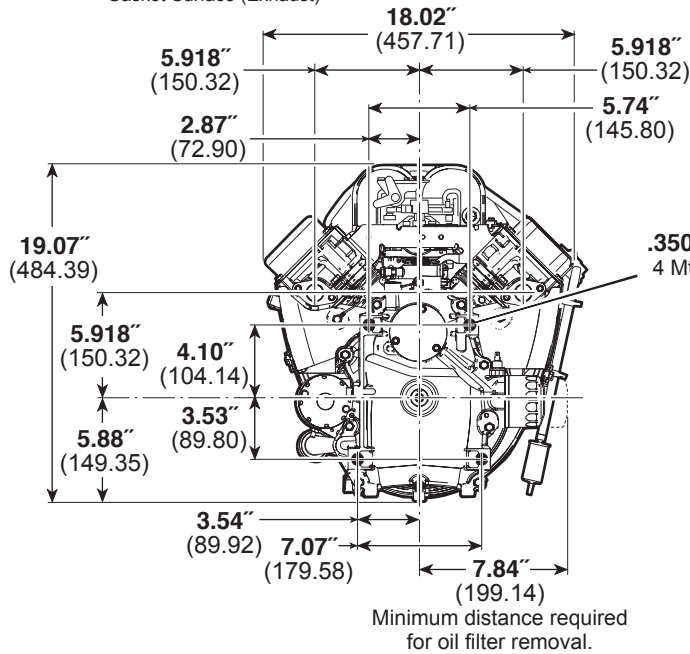
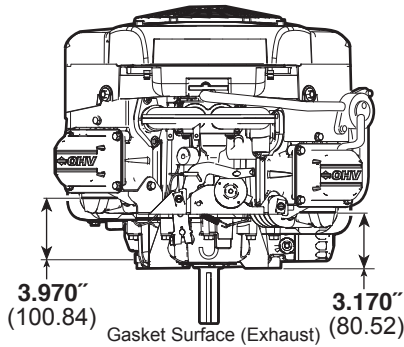

Model Type	Shipping Weight	Crankshaft	Crankshaft (P.T.O.) Extension	Dimension	Starter Position Bolt-On/Changeable	Governor	Controls	Exhaust System	Fuel Tank (Quarts)	Ground Wire Terminal	Ext. Oil Fill & Dipstick	Oil Pump w/Filter	Choke-A-Matic®	Top Governor Speed	Notes
445577															
3035	94	796237	Tapped 7/16-20, Keyway, 1" dia.	3-5/32(b)		M	R	•	■	X	X	X	X	3300	▼
3036	96	796256	Tapped 7/16-20, Keyway, 1-1/8" dia.	4-5/16(b)		M	R	•	■	X	X	X	X	3300	†
3037	96	796237	Tapped 7/16-20, Keyway, 1" dia.	3-5/32(b)		M	R	•	■	X	X	X	X	3300	†

• Exhaust manifold and muffler omitted. ■ Fuel tank omitted. † Engine equipped with 12 Volt Gear Drive Starter and 16 AMP DC Alternator.  
▼ Engine equipped with 12 Volt Gear Drive Starter and Dual Circuit Alternator. (3 AMP DC - 14 Volts AC)