

Extended Life Series® 26.0 Gross HP 724 CC

Bore 3.12 in. (79.0 mm)
Stroke 2.89 in. (73.4 mm)
Oil Capacity 64 fl. oz. (1.9 L)

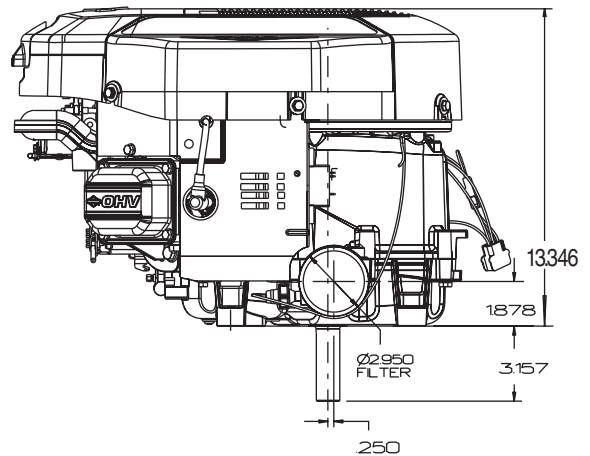
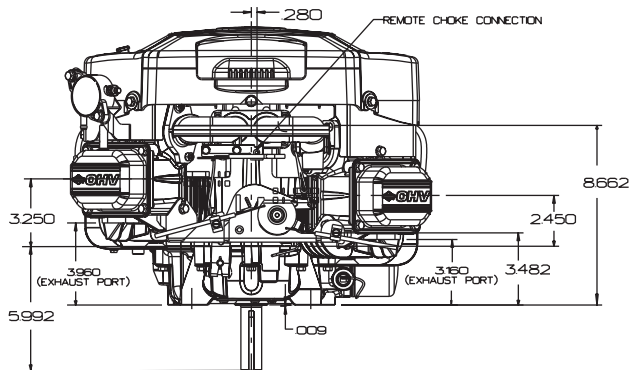
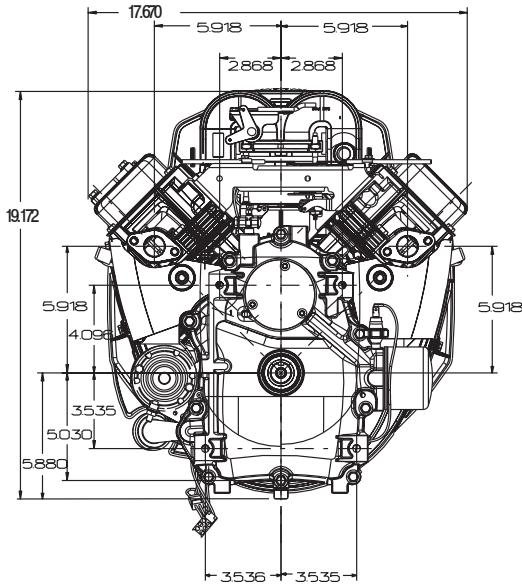

Features:

- Dura-Bore™ cast iron cylinder sleeve for extended life
- Dependable float feed type carburetor with integral fuel pump for remote mount fuel tank
- Maintenance-free Magnetron® electronic ignition for quick, dependable starts
- Dual-Clean™ air cleaner pleated paper filter with a foam pre-cleaner ensures maximum protection for extended engine life
- Full pressure lubrication with spin-on oil filter assures controlled lubrication for extended component life
- Overhead valve design (OHV) for cooler operation and longer valve life
- Platinum spark plugs for extended life
- Premium oil filter
- Buyer protection package provides two-year consumer engine warranty

Model Type	Shipping Weight	Crankshaft	Crankshaft (P.T.O.) Extension	Dimension	Starter Position Bolt-On/Changeable	Governor	Controls	Exhaust System	Fuel Tank (Quarts)	Ground Wire Terminal	Ext. Oil Fill & Dipstick	Oil Pump w/Filter	Remote Choke	Top Governor Speed	Notes
44P777															
0025	95	790136	Tapped 7/16-20, Keyway, 1" dia.	4-5/16(b)		M	R	•	■	X	X	X	X	3300	†
0026	96	790133	Tapped 7/16-20, Keyway, 1-1/8" dia.	4-5/16(b)		M	R	•	■	X	X	X	X	3300	†
0027	94	699708	Tapped 7/16-20, Keyway, 1" dia.	3-5/32(b)		M	R	•	■	X	X	X	X	3300	†

* Exhaust manifold and muffler omitted. ■ Fuel tank omitted. † Engine equipped with 12 Volt Gear Drive Starter and 16 Amp DC Alternator.