

# Commercial Series™ 27.0 Gross HP

## 810 CC

Bore 3.30 in. (83.81 mm)

Stroke 2.90 in. (73.41 mm)

Oil Capacity 64 fl. oz. (1.90 L)

## FEATURES:

- Patented 5-Step Debris Management System
- Cyclonic air filter provides debris protection and lasts 2X longer than panel air cleaners
- Increased cylinder block structure for added strength and durability
- Cooling fin inspection panels
- High radial load PTO bearing
- Full pressure lubrication with spin-on oil filter
- Buyer protection package provides two-year limited consumer engine warranty**

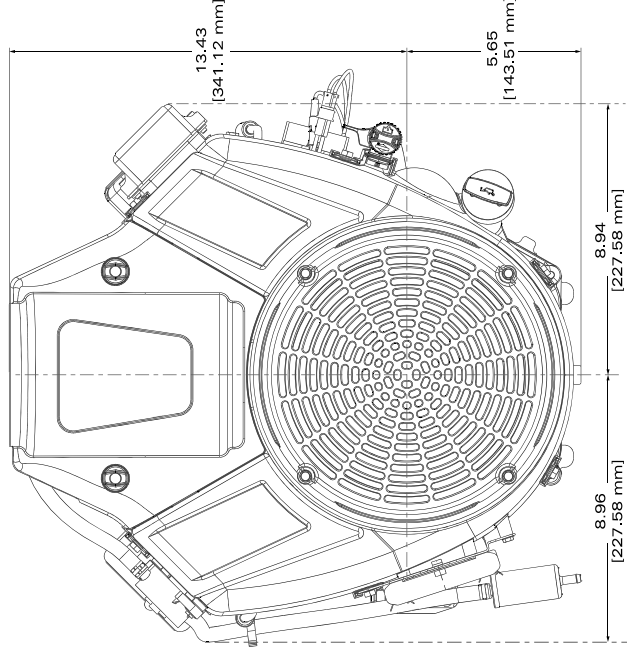
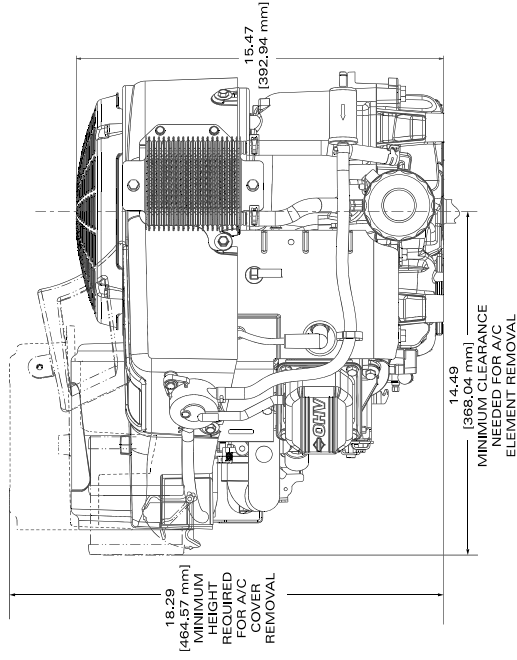

†All power levels are stated gross horsepower at 3600 RPM per SAE J1940 as rated by Briggs & Stratton.

MTT	Crankshaft #	P.T.O. Diameter	Drilled & Tapped	Keyway	Length	Starter Position	Cyclonic Filter	Controls	Oil Cooler	Fuel Pump	Oil Pump / Filter	Choke-A-Matic	ReadyStart®	Remote Choke	EFM	Alternator	Governed Speed	Notes
49T877																		
0004-G1	796855	1-1/8 in.	7/16-20	1/4-Sq.	4-19/64		X	R	X	X	X			X		16A,DC	3600	1,7,8
0015-G1	796857	1 in.	7/16-20	1/4-Sq.	3-5/32		X	R	X	X	X				X	16A,DC	3400	1,7,8
0017-G1	796857	1 in.	7/16-20	1/4-Sq.	3-5/32		X	R	X	X	X			X		16A,DC	3600	1,7,8

(1) 12 Volt Gear Drive Starter

(7) Suppress Afterfire Solenoid

(8) Static Cover Installed