

---

# Operator's Manual

---

## OH318EA (OHM90-110)

Four-Cycle Engine • Horizontal Crankshaft • Air-Cooled

### Table of Contents

IMPORTANT NOTICE! Safety Definitions .....	ii
I. General Safety Precautions .....	1
II. How to Get Service .....	3
III. Oil and Fuel Specifications .....	4
IV. Before Starting Your Engine .....	4
V. Starting Your Engine .....	7
VI. Stopping Your Engine and Short-Term Storage .....	12
VII. Maintenance .....	12
VIII. Transporting Your Engine .....	16
IX. Storing Your Engine .....	17
X. Preventing Forest, Brush and Grass Fires .....	18
XI. Maintenance Intervals.....	19
California & US EPA Emission Control Warranty Statement .....	20
Emission Control System Warranty .....	21
XII. Warranty Information .....	22

Visit our web site at [www.TecumsehPower.com](http://www.TecumsehPower.com)

- ◆ Register Your TecumsehPower Engine
  - ◆ Maintenance Tips
  - ◆ On-Line Store
  - ◆ Locate your nearest TecumsehPower Servicing Dealer
- LOG ON!*

181-719-14  
(English) 6/01/08

# IMPORTANT NOTICE!

## Safety Definitions

Statements in this manual preceded by the following words and graphics are of special significance:

### **WARNING**

Or

### **WARNING**

WARNING indicates a potentially hazardous situation which if NOT avoided, could result in death or serious injury.

### **CAUTION**

Indicates a potentially hazardous situation which, if NOT avoided, may result in minor or moderate injury.

### **CAUTION**

Indicates a potential situation which, if NOT avoided, could result in equipment or property damage.

### *NOTE*

*Refers to important information and is placed in italic type.*

It is recommended that you take special notice of all items discussed on the next two pages and wear the appropriate safety equipment.

Before operating this engine *it is your responsibility* to read this Operator's Manual. Follow these basic rules for your personal safety:

- Keep this manual handy at all times for future reference.
- Read it carefully and familiarize yourself with operating, maintenance, components and safety instructions.

## Notice Regarding Emissions

### *NOTE*

*Engines which are certified to comply with California and U.S. EPA emission regulations for SORE (Small Off Road Equipment), are certified to operate on regular unleaded gasoline, and may include the following emission control systems: (EM) Engine Modification and (TWC) Three-way Catalyst (if so equipped).*

## TecumsehPower Contact Information

For engine adjustments, repairs or warranty service NOT covered in this manual, contact your nearest Authorized TecumsehPower Servicing Dealer. Find them on our website at [www.TecumsehPower.com](http://www.TecumsehPower.com) or call TecumsehPower Company at 1-800-558-5402 for additional information.

The trademarks TECUMSEH® and the DESIGN (Native American Head logo) are registered trademarks of Tecumseh Products Company and are used by TecumsehPower Company under license from Tecumseh Products Company. TecumsehPower Company is no longer owned by Tecumseh Products Company nor is it associated or affiliated in any way with Tecumseh Products Company.

©Copyright 2006, 2008

TecumsehPower Company

All Rights Reserved

# I. General Safety Precautions

## ⚠ WARNING

Read equipment manufacturer's manual and this material thoroughly before using this engine. Failure to do so can result in serious injury or death. Consult your local Authorized TecumsehPower Servicing Dealer, call 1-800-558-5402, or go to [www.TecumsehPower.com](http://www.TecumsehPower.com) for additional information.

### A. Avoid Carbon Monoxide Poisoning

All engine exhaust contains carbon monoxide, a deadly gas. Breathing carbon monoxide can cause headaches, dizziness, drowsiness, nausea, confusion and eventually death.

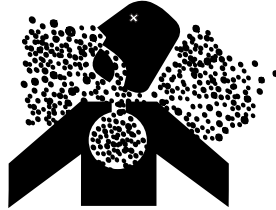

Carbon monoxide is a colorless, odorless, tasteless gas which may be present even if you DO NOT see or smell any engine exhaust. Deadly levels of carbon monoxide can collect rapidly and you can quickly be overcome and unable to save yourself. Also, deadly levels of carbon monoxide can linger for hours or days in enclosed or poorly-ventilated areas. If you experience any symptoms of carbon monoxide poisoning, leave the area immediately, get fresh air, and SEEK MEDICAL TREATMENT.

To prevent serious injury or death from carbon monoxide:

- NEVER run engine indoors. Even if you try to ventilate engine exhaust with fans or open windows and doors, carbon monoxide can rapidly reach dangerous levels.
- NEVER run engine in poorly-ventilated or partially enclosed areas such as barns, garages, basements, carports, under dwellings, or in pits.
- NEVER run engine outdoors where engine exhaust can be drawn into a building through openings such as windows and doors.

### B. Avoid Gasoline Fires

Gasoline (fuel) vapors are highly flammable and can explode. Fuel vapors can spread and be ignited by a spark or flame many feet away from engine. To prevent injury or death from fuel fires, follow these instructions:



- NEVER store engine with fuel in fuel tank inside a building with potential sources of ignition such as hot water and space heaters, clothes dryers, electric motors, etc.
- NEVER remove fuel fill cap or add fuel when engine is running.
- NEVER start or operate the engine with the fuel fill cap removed.
- Allow engine to cool before refueling.

- NEVER fill fuel tank indoors. Fill fuel tank outdoors in a well-ventilated area.
- DO NOT smoke while refueling tank.
- Use only an approved red GASOLINE container to store and dispense fuel. TecumsehPower Company recommends purchasing gasoline in containers with a capacity of 2.5 gallons or less. Small containers are easier to handle and help eliminate spillage during refueling.
- DO NOT pour fuel from engine or siphon fuel by mouth. To empty the fuel tank, see "I. Draining Fuel" instructions on page 17.

### C. Adult Supervision of Operation, Refueling and Maintenance

The manufacturer of the equipment may provide information about who is allowed to use this engine (see equipment manufacturer's manual). NOT everyone who is allowed to use this engine is capable of safely and responsibly operating, maintaining and/or fueling it. TecumsehPower Company recommends the following:

- An adult should fuel this engine. NEVER allow children to refuel this engine. See "G. Filling Fuel Tank" instructions on page 7.
- An adult should perform maintenance on this engine. See "VII. Maintenance" instructions on page 12. Only allow children to perform maintenance if an adult has determined they are experienced and capable of such operation.
- An adult should start the engine. See "G. Avoid Accidental Starts" instructions on page 2. Only allow children to start the engine if an adult has determined they are experienced and capable of such operation.
- To avoid unsupervised operation of the engine, especially by children, NEVER leave it unattended when it is running. Remove ignition key, if equipped.

### D. Stay Away from Rotating Parts

NEVER operate the engine with an unguarded engine shaft or flywheel. See Figures 1 and 2 on page 2.

The equipment manufacturer may attach a sprocket and chain or pulley and belt to the engine shaft. If these parts are NOT properly guarded, or if you are NOT sure whether they are properly guarded, DO NOT use your engine; contact the equipment manufacturer. Hands, feet, hair, jewelry, clothing, etc., can become entangled in rotating parts, leading to serious injury or death. To avoid serious injury or death, be sure the flywheel guard is in place. See Figures 1 and 2 on page 2.

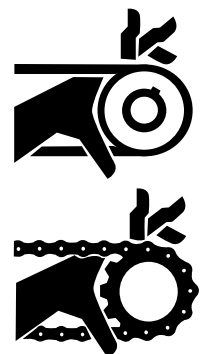

## E. DO NOT Modify Engine

To avoid serious injury or death, DO NOT modify engine in any way. Tampering with the governor setting can lead to a runaway engine and cause it to operate at unsafe speeds. NEVER tamper with factory setting of engine governor.

### ⚠ WARNING

Use of this engine on fun-carts, go-karts, or mini-bikes can result in serious injury or death. TecumsehPower Company manufactures the Power Sport line of engines for use in such applications. Consult your local Authorized TecumsehPower Servicing Dealer, call 1-800-558-5402, or visit [www.TecumsehPower.com](http://www.TecumsehPower.com) for additional information.

## F. Avoid Burns and Fire from Hot Surfaces

The muffler and other engine parts become extremely hot during operation and remain hot after the engine has stopped.



- To avoid severe burns on contact, STAY AWAY from hot areas of engine. DO NOT operate the engine without the muffler guard in place, if equipped.
- To reduce the risk of fire keep all materials that can burn, including grass and leaves, away from muffler and rest of engine. DO NOT operate, idle or park engine powered equipment in long dry grass or other dry ground cover.

## G. Avoid Accidental Starts

To prevent accidental starting when working on equipment always:

- Carefully disconnect spark plug wire and keep it away from spark plug. See Figures 3 and 4.
  - Keep the disconnected spark plug wire securely away from metal parts where arcing could occur.
  - Carefully attach the spark plug wire to the grounding post, if provided.
- Disconnect battery at negative terminal first, if engine is equipped with a DC electric starter.
- Turn all engine switches to “OFF” position.
- Remove ignition key, if provided.

## H. Use Hearing Protection

Engine noise may cause hearing damage. Always wear hearing protection when operating an engine.



Figure 1. DO NOT Use Without Engine Shaft Guard

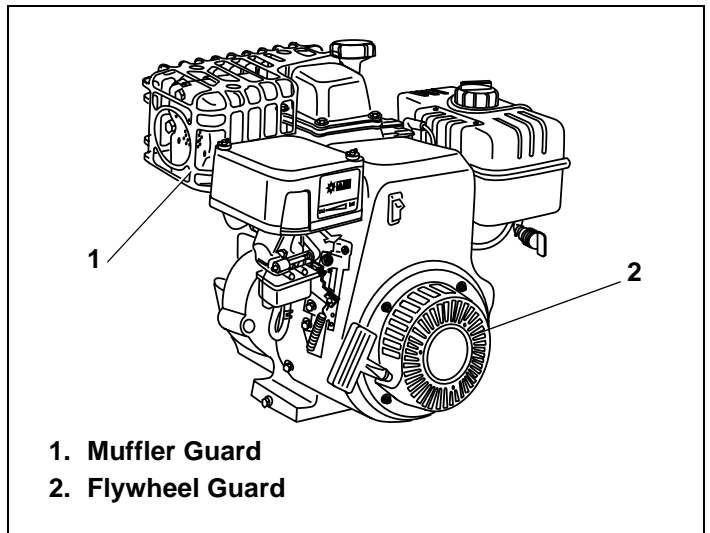

Figure 2. Typical Engine Guard Locations

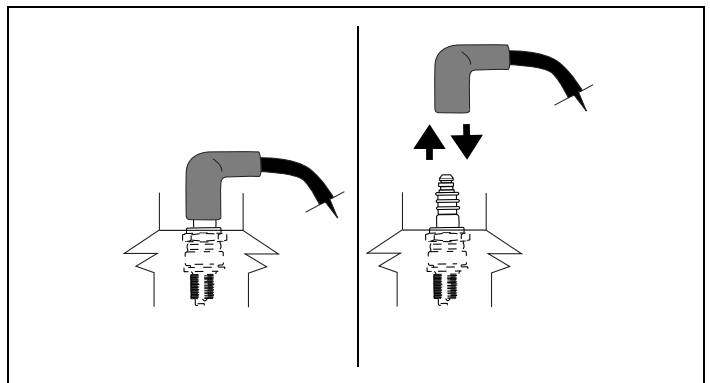

Figure 3. Disconnecting/Connecting Spark Plug

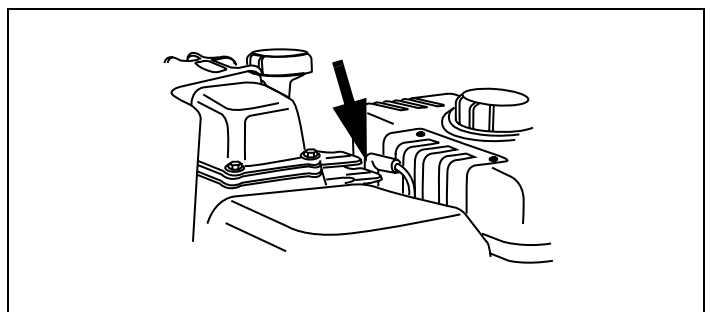

Figure 4. Typical Spark Plug Connection

## II. How to Get Service

For engine adjustments, repairs or warranty service NOT covered in this manual, contact your nearest Authorized TecumsehPower Servicing Dealer. Find them on our website at [www.TecumsehPower.com](http://www.TecumsehPower.com) or call TecumsehPower Company at 1-800-558-5402 for additional information.

Visit our web site at [www.TecumsehPower.com](http://www.TecumsehPower.com)

- ♦ Register Your TecumsehPower Engine
- ♦ Maintenance Tips
- ♦ On-Line Store
- ♦ Locate your nearest TecumsehPower Servicing Dealer

LOG ON!

### A. Engine Identification Decal

A sample engine identification decal is located in the next column and indicates the engine's model number, specification and date of manufacture (DOM). See Figure 5.

#### NOTES

Please look at the decal on your engine.

Fill in the engine information in the spaces provided for future reference.

The engine identification decal also includes engine life specifications for the emissions-related useful life period of your engine. This period relates to the emission compliance life as certified by EPA and/or CARB.

- OH models are designated as "C" 250 hours, "B" 500 hours and "A" 1000 hours.

### B. Technician's Handbook

If you have a general understanding of internal combustion engines and wish to repair and service your engine and/or engine emission control systems yourself, a Technician's Handbook is available from your Authorized TecumsehPower Servicing Dealer. See Figure 6. This handbook covers repairs and adjustments not covered within this Operator's Manual, and it is intended for individuals who have had adequate training, experience and who practice proper tool usage. Service procedures should be clearly understood and practiced when servicing TecumsehPower engines.

- Order as part #695244A or #740043 for OH models.

TecumsehPower Company manufactures and is responsible only for the engine used on this power equipment. If repair or service is needed for anything other than the engine, contact the service source recommended by the equipment manufacturer.



ENGINE  
MODEL: \_\_\_\_\_

SPEC: \_\_\_\_\_

DOM: \_\_\_\_\_

Figure 5. Engine Identification Decal



Figure 6. Technician's Handbook

### III. Oil and Fuel Specifications

#### A. Oil

To operate engine you need to use a clean, high quality, detergent oil. For recommended engine oil, see Table 1. In addition, you need to be sure the oil sump contains the correct amount of oil to operate properly.

##### NOTES

The oil sump capacity for OH318EA models is 26 ounces or 1-5/8 U.S. Pints (.78 liters).

Be sure original container is marked A.P.I. Service "SL/SJ".

Using multigrade oil above 32°F (0°C) will increase oil consumption. SAE 10W40 is NOT recommended.

Special-formulated oils are available at your Authorized TecumsehPower Servicing Dealer.

#### B. Fuel

Use unleaded regular, unleaded premium or reformulated automotive fuel only. You may use gasoline containing the components identified in Table 2.

- DO NOT use leaded fuel.
- Fuel must be fresh and clean. NEVER use fuel left over from last season or stored for long periods.
- NEVER mix oil with fuel.
- DO NOT use fuel containing Methanol (Wood Alcohol).

##### CAUTION

The use of alternative fuels such as E85 or E20 are NOT recommended for use in TecumsehPower engines. Alternative fuels with high alcohol content can cause hard starting, poor engine performance, and may cause internal engine damage.

##### NOTE

Damage and/or performance problems that occur from use of fuels, other than those listed in the Operator's Manuals will not be considered warranty.

### IV. Before Starting Your Engine

#### A. Checking Oil Level

To avoid engine damage, it is important to:

- Check oil level before each use and every 5 operating hours when engine is warm. Check oil level more frequently during engine break-in.
- Keep oil level between "FULL" and "ADD" marks on dipstick. See Figure 7.
- Be sure oil fill cap is tightened securely.

##### NOTES

DO NOT overfill oil filler. Doing so may result in oil carry-over to the air cleaner and equipment and cause malfunction or damage.

DO NOT allow oil level to fall below the "ADD" mark on dipstick. Doing so may result in equipment malfunction or damage.

Contact your Authorized TecumsehPower Servicing Dealer for TecumsehPower Oil.

Table 1. Recommended Oil

TecumsehPower Recommended Oil Usage										
					Straight Grade TecumsehPower Part No. 730225A or SAE 30W					
			Multi Grade TecumsehPower Part No. 730226A or SAE 5W30 or SAE 10W							
			TecumsehPower Synthetic Part No. 730263 or SAE 0W30							
-30°F	-20°F	0°F	20°F	32°F	40°F	60°F	80°F	100°F		
-30°C	-20°C	-10°C	0°C	10°C	20°C	30°C	40°C			

Table 2. Recommended Fuel

Fuel Component	Percentage
Ethanol	10%
Grain Alcohol ("Gasohol")	10%
MTBE (Methyl Tertiary Butyl Ether)	15%
ETBE (Ethyl Tertiary Butyl Ether)	15%

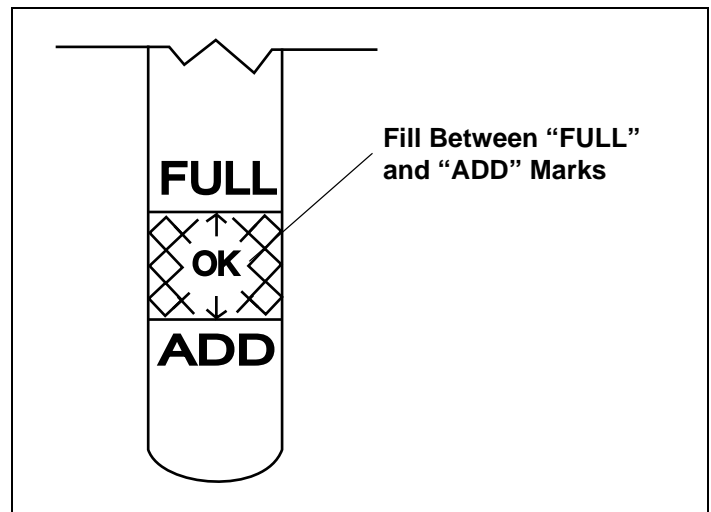

Figure 7. Engine Oil Level

## B. Filling Oil Sump

### I. Oil Fill Cap/Dipstick

If your engine has an oil fill cap/dipstick go to step 1. If your engine does NOT have an oil fill cap/dipstick, see "II. Oil Fill Cap/Plug" instructions below.

1. Be sure engine is upright and level.
2. Unscrew oil fill cap/dipstick from oil filler tube and wipe dipstick clean. See Figure 8.
3. Screw oil fill cap/dipstick back into oil filler tube. Tighten securely.
4. Unscrew and remove oil fill cap/dipstick from oil filler tube. Note oil level. If oil reading on dipstick is below "ADD" mark, slowly add oil to reach "FULL" level. See Figure 7 on page 4. Afterward, continue reading instructions below.
5. Screw oil fill cap/dipstick back into oil filler tube. Tighten securely.
6. Wipe away any spilled oil.

#### NOTE

To change oil for engines with an oil fill cap/dipstick, see "A. Checking and Changing Oil" instructions on page 13.

### II. Oil Fill Cap/Plug

If your engine does NOT have an oil fill cap/dipstick, go to step 1. If your engine has an oil fill cap/dipstick, see "I. Oil Fill Cap/Dipstick" instructions above.

1. Be sure engine is upright and level.
2. Clean area around oil fill cap/plug. See Figure 9.
3. Unscrew oil fill cap/plug.
4. Add oil to overflow point, making sure to avoid spilling.
5. Screw oil fill cap/plug back into oil fill hole. Tighten securely.
6. Wipe away any spilled oil.

#### NOTE

To change oil for engines with an oil fill cap/plug, see "A. Checking and Changing Oil" instructions on page 13.

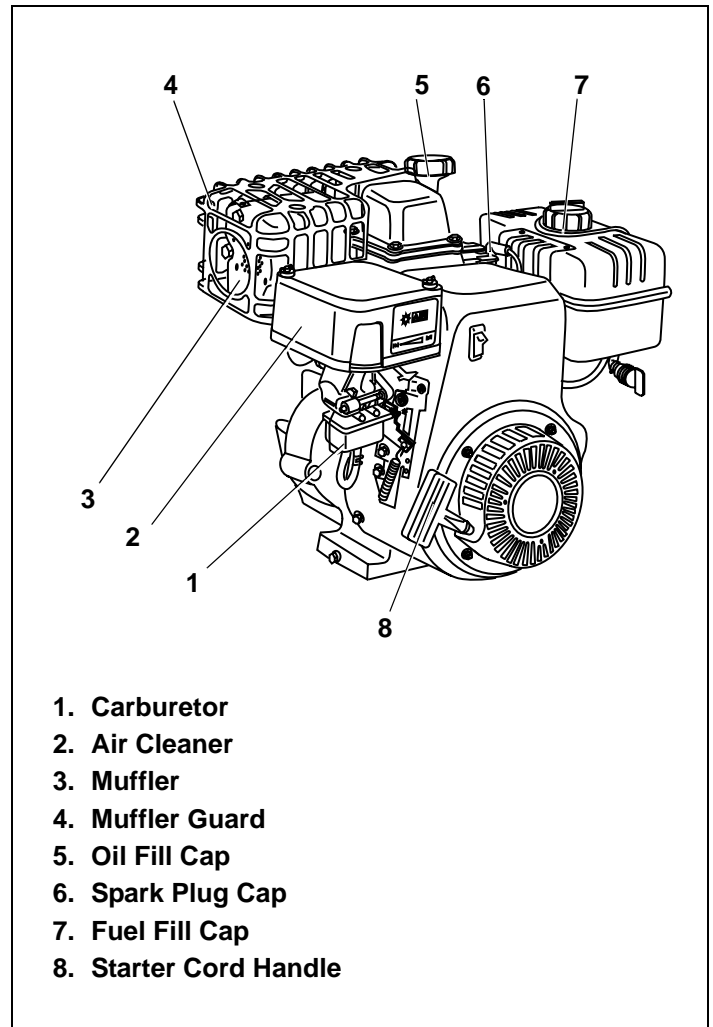

Figure 8. Engine Components

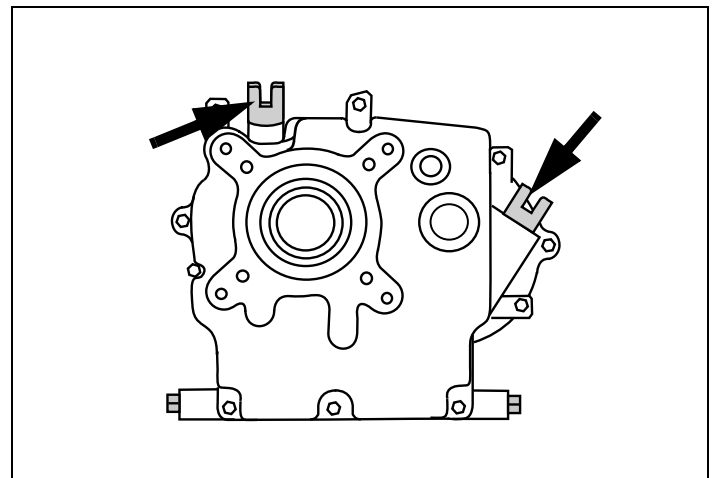

Figure 9. Oil Fill Locations

### C. Engine Stop Switch

Some engines are equipped with an optional Stop Switch. This rocker switch is used to shut off the ignition that supplies the spark plug with power. Pressing the "OFF" position will turn the engine off when it is running. This switch must be in the "ON" position or the engine will not start. See Figure 10.

### D. Low Oil Shutdown Switch

Some engines are equipped with an optional Low Oil Shutdown Switch. This is a lighted rocker switch that is connected to a float switch in the engine crankcase. When oil level drops below a predetermined level, the float switch cuts off current to the spark plug and the engine stops running. Oil must be added to the engine to bring the oil to the proper level before the engine will start. If an attempt is made to start the engine before oil is added, the switch will flash as the engine rotates, and the engine will not start. See Figure 11.

Pressing the "OFF" position of the Shutdown Switch while the engine is running, will turn the engine off. The engine will not start with the switch in the "OFF" position.

### E. Low Oil Shutdown Light

Some engines are equipped with an optional Low Oil Shutdown System that includes a light but does not include a rocker switch. The float switch in this system will shut the engine off while it is running if the oil level in the crankcase falls below a predetermined level. Oil must be added to the engine to bring the oil to the proper level before the engine will start. If an attempt is made to start the engine before oil is added, the light will flash as the engine rotates, and the engine will not start. See Figure 11.

### F. Low Oil Shutdown System

Some engines are equipped with an optional Low Oil Shutdown System that does not have a rocker switch or a light. The float switch in this system will shut the engine off while it is running if the oil level in the crankcase falls below a predetermined level. Oil must be added to the engine to bring the oil to the proper level before the engine will start.

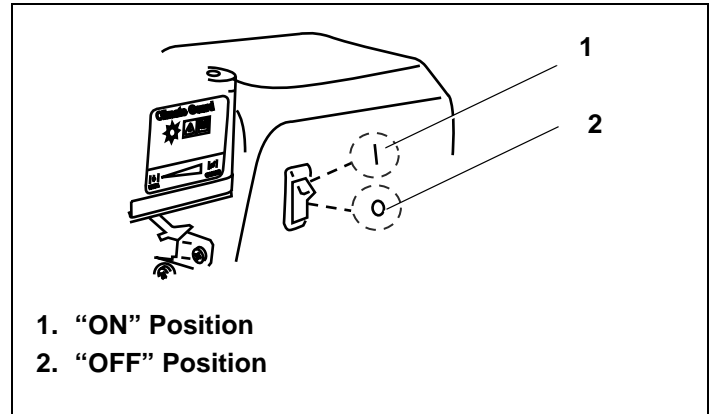

Figure 10. Engine Stop Switch

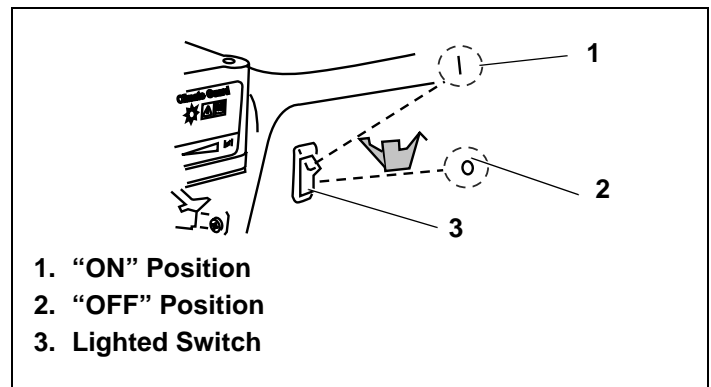

Figure 11. Low Oil Shutdown Switch



## G. Filling Fuel Tank

**WARNING** An adult should fuel this engine. NEVER allow children to refuel this engine. Gasoline (fuel) vapors are highly flammable and can explode. Fuel vapors can spread and be ignited by a spark or flame many feet away from engine. To prevent injury or death from fuel fires, follow these instructions:

1. Stop engine and allow it to cool before refueling.
2. Be sure engine is outdoors and in a well-ventilated area.
3. Clean area around fuel fill cap and remove fuel fill cap. See Figure 8 on page 5. Afterward, continue reading instructions below.

### NOTE

For recommended fuel, see Table 2 and “III. Oil and Fuel Specifications” instructions on page 4. Afterward, continue reading instructions below.

4. Using an approved red GASOLINE container, add fuel slowly, being careful to avoid spilling. DO NOT overfill fuel tank. Leave space in the tank to allow fuel to expand without overflowing.
5. Replace fuel fill cap securely and wipe up spilled fuel before starting engine. If fuel is spilled DO NOT start engine. Move machine away from area of spillage. Avoid creating any source of ignition until fuel vapors are gone.

### NOTE

Replace a damaged or missing fuel fill cap only with a genuine TecumsehPower replacement Fuel Fill Cap. Failure to do so may **VOID YOUR WARRANTY**. See Figure 12.

6. Be sure fuel valve, if present (see equipment manufacturer’s instructions) is open. See Figure 13.

## V. Starting Your Engine

**WARNING** To avoid serious injury or death, an adult should start this engine. Only allow children to start engine if an adult has determined they are experienced and capable of such operation.

**WARNING** If you are unable to start this engine after following instructions in this manual, contact your Authorized TecumsehPower Servicing Dealer. To avoid serious burn injuries or damage to your engine, DO NOT attempt to start or troubleshoot this engine in any other way. For example:

- DO NOT use starting fluid.
- DO NOT spray flammable vapors into carburetor or onto air cleaner.
- DO NOT put flammable liquids into carburetor or onto air cleaner.
- DO NOT operate engine or pull on starter rope with spark plug removed. Fuel can spray from spark plug hole and ignite.

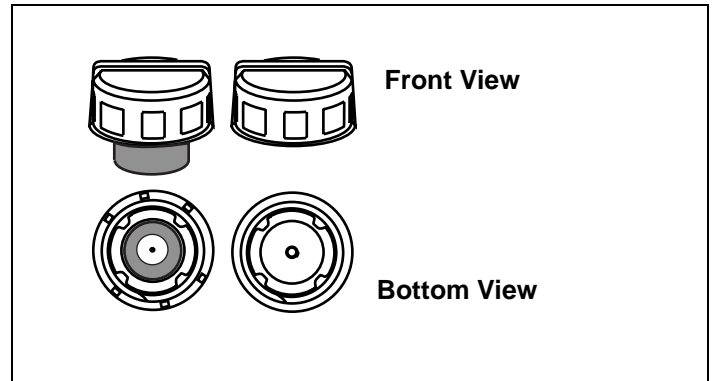

Figure 12. Possible Fuel Fill Cap(s)

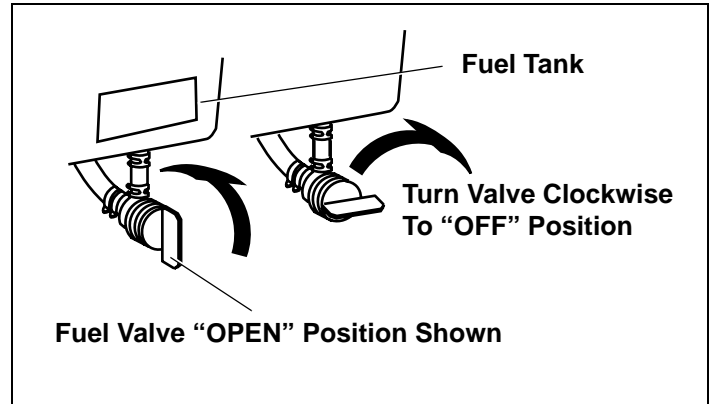

Figure 13. Fuel Valve Positions

This section contains starting instructions for several different types of engines. In order to locate the instructions that apply to your engine, first determine what type of starter you have. If you have an electric starter, see "A. Engines with Electric Starters" instructions. If you have a manual recoil starter, see "B. Engines with Recoil Starters" instructions on page 10.

## A. Engines with Electric Starters

1. To avoid carbon monoxide poisoning, be sure engine is outdoors in a well-ventilated area.
2. Be sure fuel valve, if present (see equipment manufacturer's instructions) is open and all switches are on. See Figure 14.
3. Move engine speed control to "FAST" position. See Figures 15 thru 17.
4. Set choke control to "FULL CHOKE" position (see equipment manufacturer's instructions). See Figures 18 thru 20 on page 9. Afterward, continue reading instructions below.

### NOTE

*If restarting a warm engine after a short shutdown, move engine speed control to "FAST" position and move choke control to "NO CHOKE" position.*

5. Push starter button or turn ignition switch key (see equipment manufacturer's instructions) to start engine.

### NOTE

*DO NOT operate an electric starter for more than 5 seconds each attempt.*

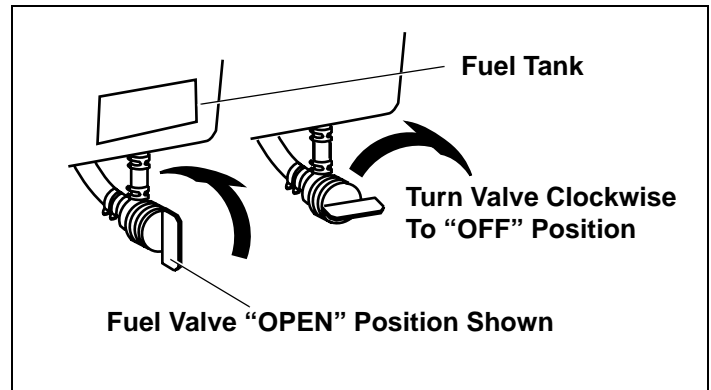

Figure 14. Fuel Valve Positions

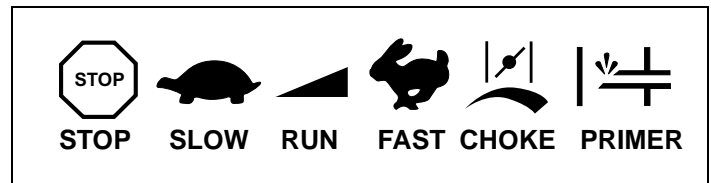

Figure 15. Typical Engine Symbols

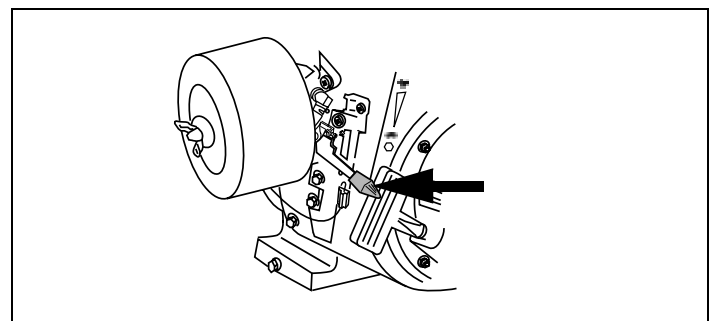

Figure 16. Engine Mounted Speed Control

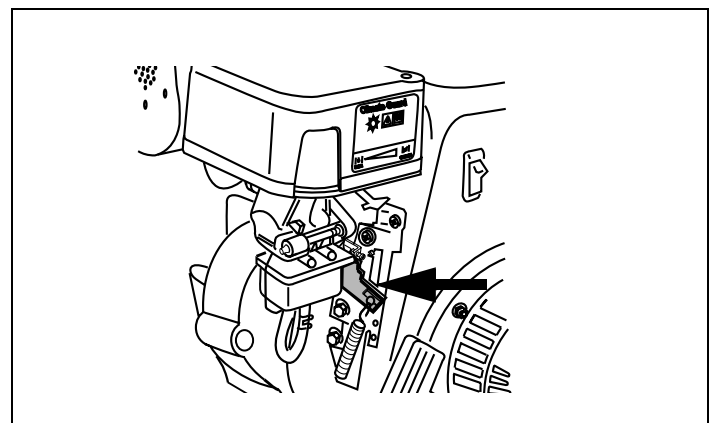

Figure 17. Engine Components

6. When engine starts:
  - a. Release starter button or ignition switch key.
  - b. Momentarily move choke control to "1/2 CHOKE" position until engine runs smoothly. See Figures 18 thru 20.
  - c. Next, move choke control to "NO CHOKE" position. See Figures 18 thru 20.
7. Move engine speed control to desired speed in "RUN" range. See Figure 15 on page 8. Afterward, continue reading instructions below.

**NOTES**

*If engine starts but falters when choke control is moved to "NO CHOKE" position:*

- a. Momentarily move choke control back to "FULL CHOKE" position. See Figures 18 thru 20.
- b. Next, move choke control to "1/2 CHOKE" position until engine runs smoothly.
- c. Finally, move choke control to "NO CHOKE" position.

*If engine dies after choke control is moved to "NO CHOKE" position repeat steps 2 thru 7 to restart engine.*

8. If engine fires but does not continue to run, move choke control to "NO CHOKE" position and start engine.
9. If engine fails to start after 3 attempts in the "NO CHOKE" position, move choke control to "FULL CHOKE" position and start engine.
10. If engine does not start after following steps 1 thru 9, contact your Authorized TecumsehPower Servicing Dealer. DO NOT attempt to start or troubleshoot this engine in any other way.

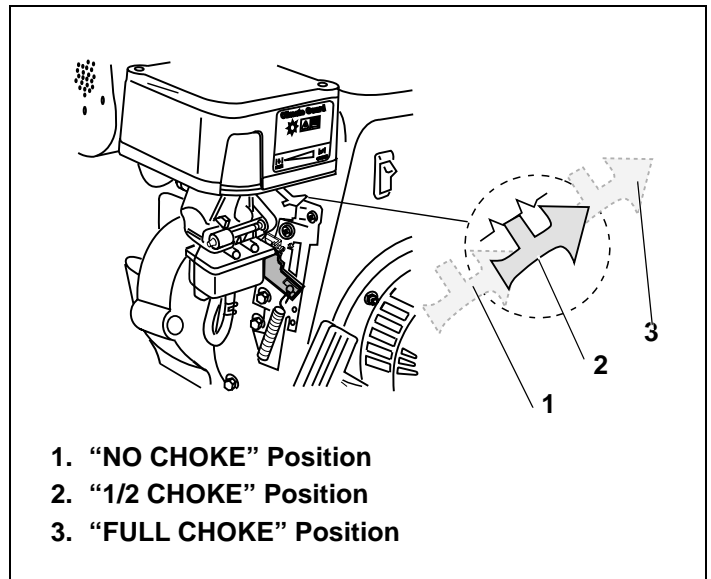

1. "NO CHOKE" Position
2. "1/2 CHOKE" Position
3. "FULL CHOKE" Position

**Figure 18. OH Choke Control Positions**

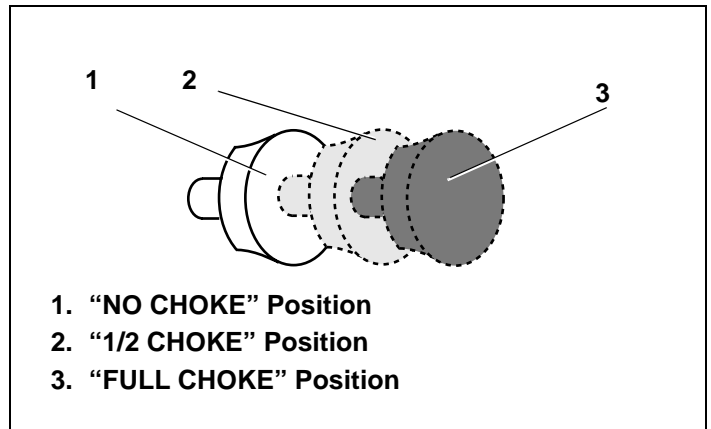

1. "NO CHOKE" Position
2. "1/2 CHOKE" Position
3. "FULL CHOKE" Position

**Figure 19. Remote Choke Control Positions**

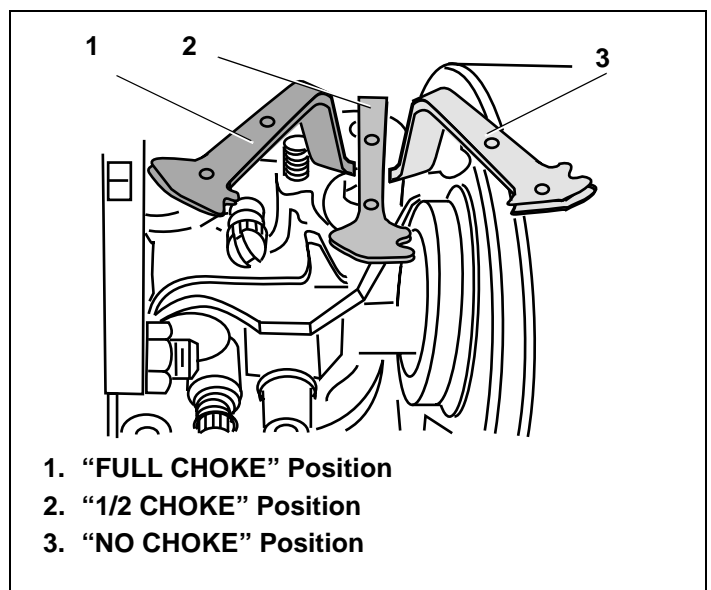

1. "FULL CHOKE" Position
2. "1/2 CHOKE" Position
3. "NO CHOKE" Position

**Figure 20. OH Choke Control Positions**

## B. Engines with Recoil Starters

1. To avoid carbon monoxide poisoning, be sure engine is outdoors in a well-ventilated area.
2. Be sure fuel valve, if present (see equipment manufacturer's instructions) is open and all switches are on.
3. Move engine speed control to "FAST" position. See Figures 21 thru 23
4. Set choke control to "FULL CHOKE" position (see equipment manufacturer's instructions). See Figures 24 thru 26. Afterward, continue reading instructions below.

### NOTE

*If restarting a warm engine after a short shutdown, move engine speed control to "FAST" position and move choke control to "NO CHOKE" position.*

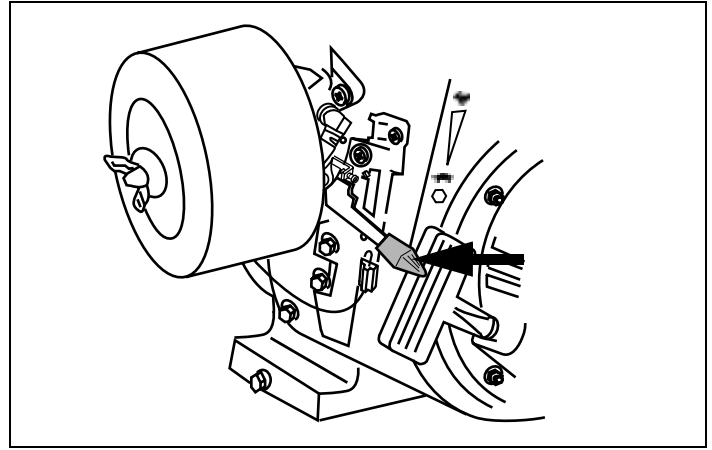

Figure 21. Engine Mounted Speed Control

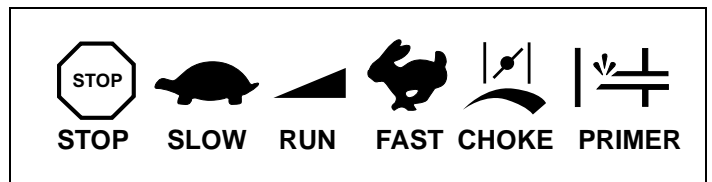

Figure 22. Typical Engine Symbols

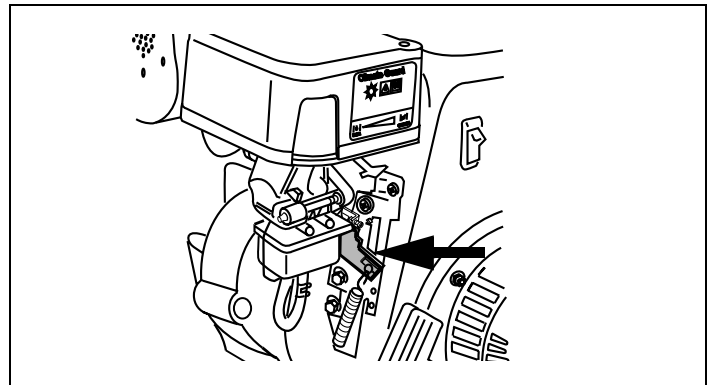

Figure 23. Engine Components

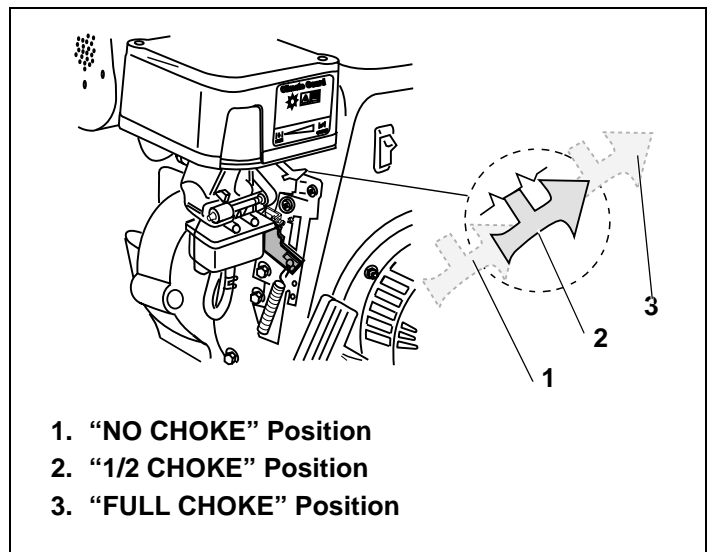

Figure 24. Choke Control Option "A"

**WARNING**

When pulling starter rope, the rope can unexpectedly jerk back toward engine causing serious injury. To avoid this risk, carefully follow these instructions:

5. Grasp starter cord handle. See Figure 27.
  - a. Pull rope out slowly until you feel drag.
  - b. Without allowing the rope to retract, continue pulling rope with one rapid full arm stroke.
  - c. Return rope *slowly* to original position.

**NOTE**

Following the instructions listed in the steps above avoids potential damage to the recoil mechanism.

6. When engine starts:
  - a. Momentarily move choke control to "1/2 CHOKE" position until engine runs smoothly. See Figures 24 thru 26.
  - b. Next, move choke control to "NO CHOKE" position.
  - c. Finally, move engine speed control to desired speed in "RUN" range.

**NOTES**

If engine starts but falters when choke control is moved to "NO CHOKE" position:

- a. Momentarily move choke control back to "FULL CHOKE" position.
- b. Next, move choke control to "1/2 CHOKE" position until engine runs smoothly.
- c. Finally, move choke control to "NO CHOKE" position.

If engine dies after choke control is moved to "NO CHOKE" position repeat steps 2 thru 6 to restart engine.

7. If engine fires but does not continue to run, move choke control to "NO CHOKE" position and start engine.
8. If engine fails to start after 3 attempts in the "NO CHOKE" position, move choke control to "FULL CHOKE" position and start engine.
9. If engine does not start after following steps 1 thru 8, contact your Authorized TecumsehPower Servicing Dealer. DO NOT attempt to start or troubleshoot this engine in any other way.

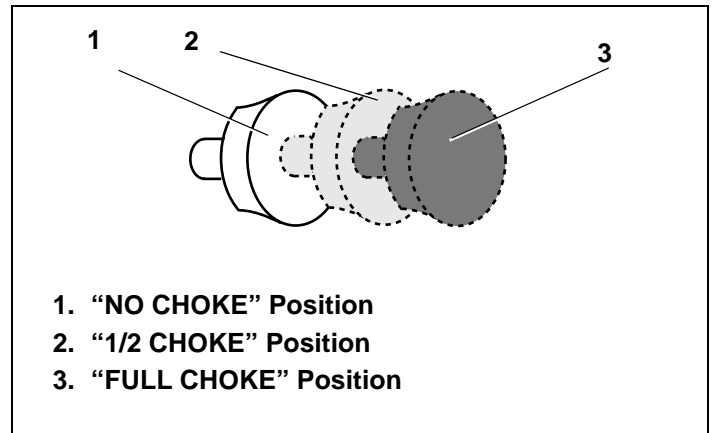

Figure 25. Remote Choke Control Positions

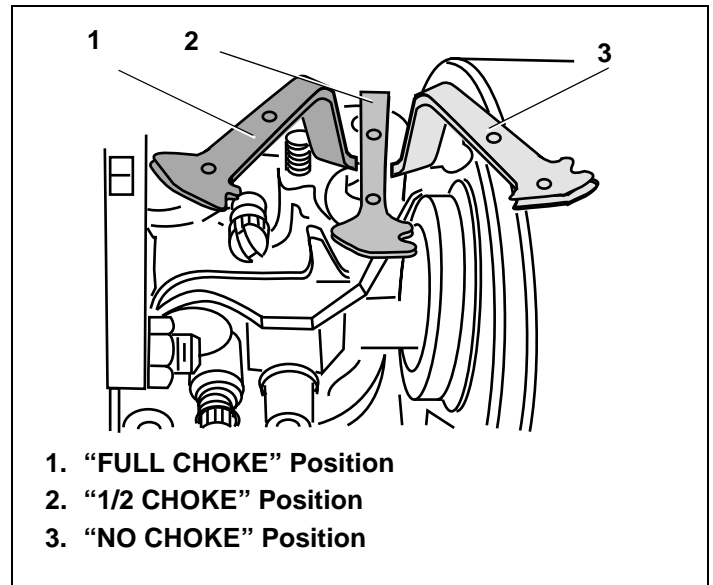

Figure 26. OH Choke Control Positions

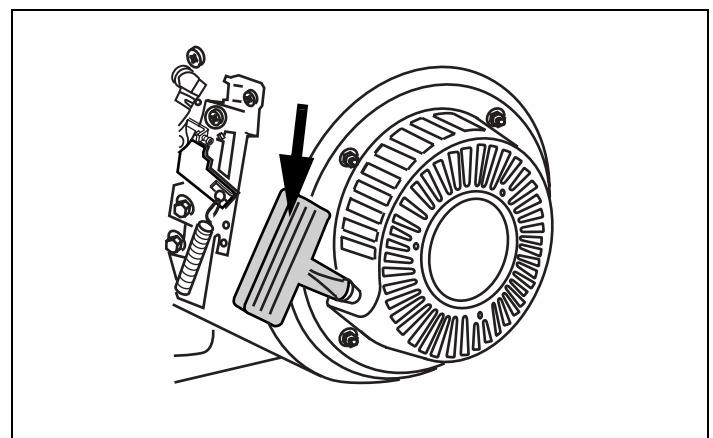

Figure 27. Starter Cord Handle

## VI. Stopping Your Engine and Short-Term Storage

Stop engine according to equipment manufacturer's instructions.

**WARNING** To avoid unsupervised operation of an engine, especially by children, NEVER leave it unattended when it is running. Always turn off the engine after use and remove ignition key, if provided. Failure to do so may lead to serious injury or death.

**WARNING** NEVER store engine with fuel in the fuel tank inside a building with potential sources of ignition such as hot water or space heaters, clothes dryers, electric motors, etc. Doing so may lead to an explosion resulting in death or serious injury.

## VII. Maintenance

**WARNING** To avoid serious injury or death, an adult should perform maintenance on this engine. Only allow children to perform maintenance if an adult has determined they are experienced and capable of such operation.

**WARNING** To prevent accidental starting when working on equipment, always:

- Carefully disconnect spark plug wire and keep it away from spark plug. See Figures 3 and 4 on page 2. Afterward, continue reading instructions below.
  - Keep the disconnected spark plug wire securely away from metal parts where arcing could occur.
  - Carefully attach the spark plug wire to the grounding post, if provided.
- Disconnect battery at negative terminal first, if engine is equipped with a DC electric starter.
- Turn all engine switches to "OFF" position.
- Remove ignition key, if provided.

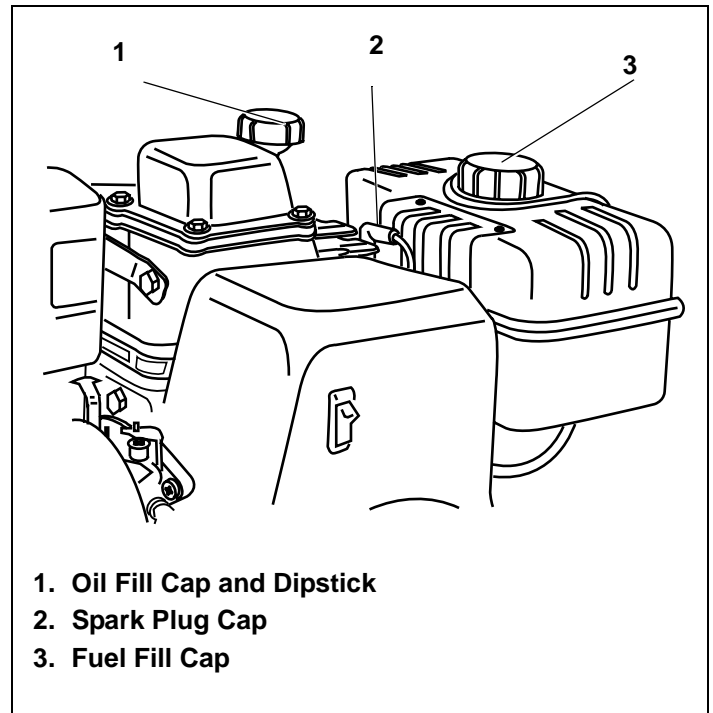

1. Oil Fill Cap and Dipstick
2. Spark Plug Cap
3. Fuel Fill Cap

Figure 28. Engine Components

## A. Checking and Changing Oil

To avoid engine damage, it is important to:

- Check oil level before each use and every 5 operating hours when engine is warm. See "A. Checking Oil Level" instructions on page 4. Afterward, continue reading instructions below.
- Change oil after first 2 operating hours and every 50 operating hours thereafter; more often if operated in extremely dusty or dirty conditions. Engine should still be warm but NOT hot from recent use.

### NOTES

To check oil on engines with an oil fill cap/dipstick, see "I. Oil Fill Cap/Dipstick" instructions on page 5.

To check oil on engines with an oil fill cap/plug, see "II. Oil Fill Cap/Plug" instructions on page 5.

1. Be sure you find the correct drain plug location, if provided. See Figure 29.
2. Carefully disconnect spark plug wire and keep it away from spark plug. See "G. Avoid Accidental Starts" instructions on page 2. Afterward, continue reading instructions below.
  - Keep the disconnected spark plug wire securely away from metal parts where arcing could occur.
  - Carefully attach the spark plug wire to the grounding post, if provided.
3. Be sure the fuel fill cap is on and tightened securely.
4. Clean area around oil drain plug. See Figure 29.
5. Place approved recyclable oil container under oil drain plug, if present.
6. Remove oil drain plug, if present. See Figure 29.
7. Tip engine to position the oil flow, so it will drain from the lowest point on the engine (see equipment manufacturer's instructions).
8. Drain oil into an approved recyclable oil container.



### NOTE

Used oil must be disposed of at a proper collection center.

9. Install oil drain plug and tighten securely.
10. Fill with recommended oil. See "III. Oil and Fuel Specifications" instructions and Table 1 on page 4. Afterward, continue reading instructions below.
11. Wipe away any spilled oil.
12. Carefully disconnect spark plug wire from grounding post, if provided.
13. Connect spark plug wire to spark plug before attempting to start engine. See Figure 3 on page 2.

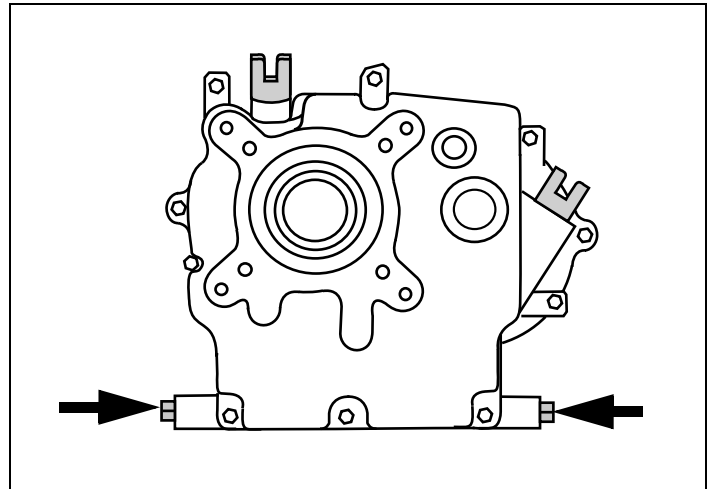

Figure 29. Oil Drain Plug Locations

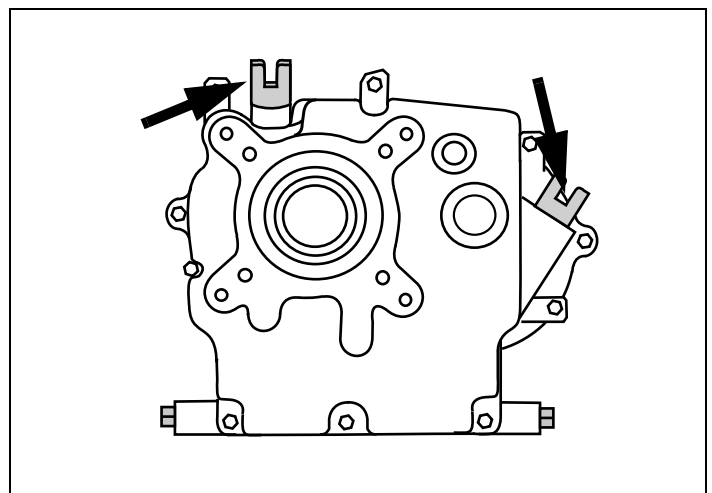

Figure 30. Oil Fill Locations

## B. Removing Debris from Engine

Before each use, remove grass clippings, dirt and debris from the following areas:

- Levers and Linkage
- Cooling Fins
- Air Intake Screen
- Guards

Removing debris will insure adequate cooling, correct engine speed and reduce the risk of fire. See Figure 31.

## C. Spark Plug

Check spark plug yearly or every 100 operating hours.

1. Clean area around spark plug.
2. Remove and inspect spark plug.
3. Replace spark plug if porcelain is cracked or if electrodes are:
  - Pitted
  - Burned
  - Fouled with Deposits
4. Check electrode gap with wire feeler gauge and set gap to—.030 in. (0.76 mm) if necessary. See Figure 32.
5. Install spark plug and tighten securely.

### NOTE

A resistor spark plug must be used for replacement. Contact your Authorized TecumsehPower Servicing Dealer for a genuine replacement Resistor Spark Plug.

## D. Cleaning/Replacing Air Cleaner

Your engine has an air cleaner which helps prevent premature engine wear and failure. NEVER run engine without complete air cleaner installed on engine. Your air cleaner periodically needs to be cleaned or replaced.

### NOTE

Contact your Authorized TecumsehPower Servicing Dealer for a genuine replacement Air Cleaner.

### I. Servicing Foam Filters

Clean foam pre-filter every 3 months or every 25 operating hours. Clean daily if used in extremely dusty conditions. After removing the pre-filter, follow these cleaning instructions below:

1. Wash in warm water and detergent solution then press (DO NOT twist) until all dirt is removed.
2. Rinse thoroughly until water is clear.
3. Wrap in a clean cloth and press (DO NOT twist) until completely dry.

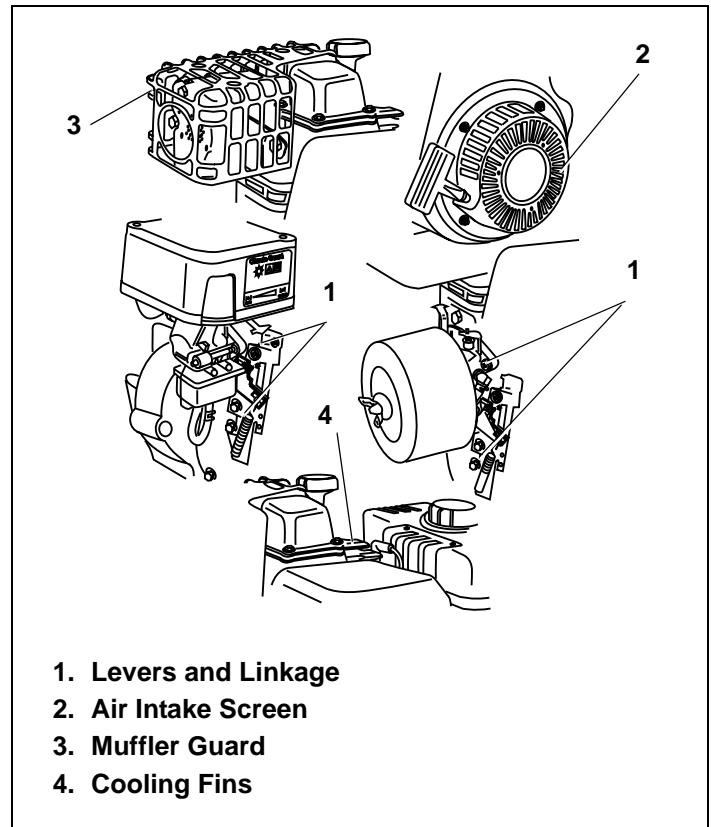

Figure 31. Debris Removal Areas

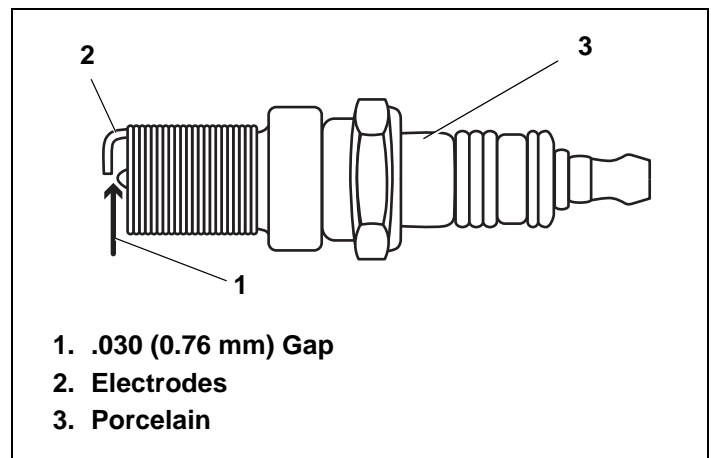

Figure 32. Resistor Spark Plug

### NOTE

DO NOT oil foam pre-filter.

4. Replace foam pre-filter onto paper filter.

### II. Servicing Paper Filters

Paper filters cannot be cleaned and must be replaced once a year or every 100 operating hours; more often if used in extremely dusty conditions. Replacement filters are available at an Authorized TecumsehPower Servicing Dealer.

### NOTE

DO NOT put oil on or clean a paper filter.



### III. Removal and Installation of OH318EA Air Filters

1. Remove wing nuts and air cleaner cover. See Figure 33.
2. Remove foam filter from paper filter.
3. Remove paper filter from base.
4. Inspect filters for discoloration or dirt accumulation. If either is present, see "I. Servicing Foam Filters" and/or "II. Servicing Paper Filters" instructions on page 14. Afterward, continue reading instructions below.
5. Clean inside of base and air cleaner cover thoroughly.
6. Install paper filter into base.
7. Install foam filter onto paper filter.
8. Install air cleaner cover on base.
9. Install wing nuts and tighten securely.

### E. Anti-Icing Baffle

Some engines may be equipped with an anti-icing air cleaner baffle that prevents ice from forming in the carburetor when the engine is run at temperatures below 32°F (0°C).

Engines equipped with the baffle will have an opening which draws warm air from the muffler into the air cleaner housing. To work effectively, it is necessary for the baffle to block cold air from entering the air cleaner.

#### NOTE

Be sure air cleaner cover is in correct "WINTER" or "SUMMER" position before operation.

#### At Temperatures of 32°F (0°C) and Below

1. Remove wing nuts from air cleaner cover. See Figure 33.
2. Remove air cleaner cover from base.
3. Rotate air cleaner cover in "WINTER" position shown. See Figure 34.
4. Install air cleaner cover onto base.

#### NOTE

Be sure air cleaner cover is in correct "WINTER" position.

5. Install wing nuts and tighten securely.

#### At Temperatures Above 32°F (0°C)

1. Remove wing nuts from air cleaner cover. See Figure 33.
2. Remove air cleaner cover from base.
3. Rotate air cleaner cover in "SUMMER" position shown. See Figure 34.
4. Install air cleaner cover onto base.

#### NOTE

Be sure air cleaner cover is in correct "SUMMER" position.

5. Install wing nuts and tighten securely.

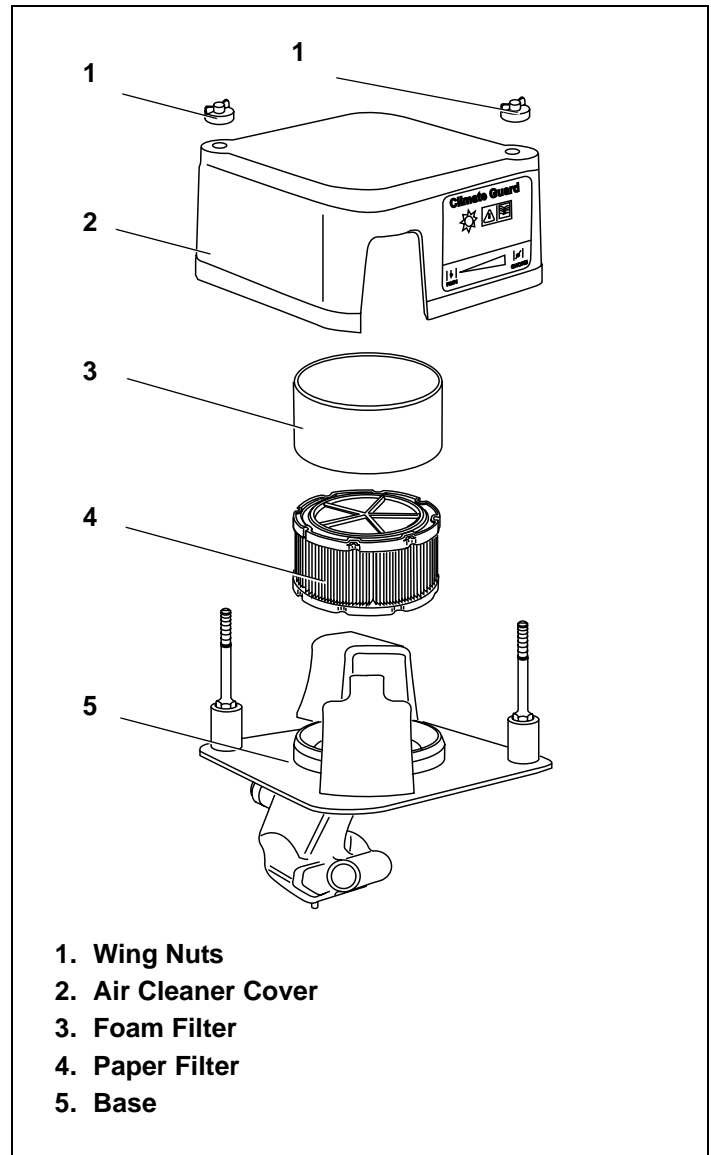

Figure 33. Climate Guard Assembly

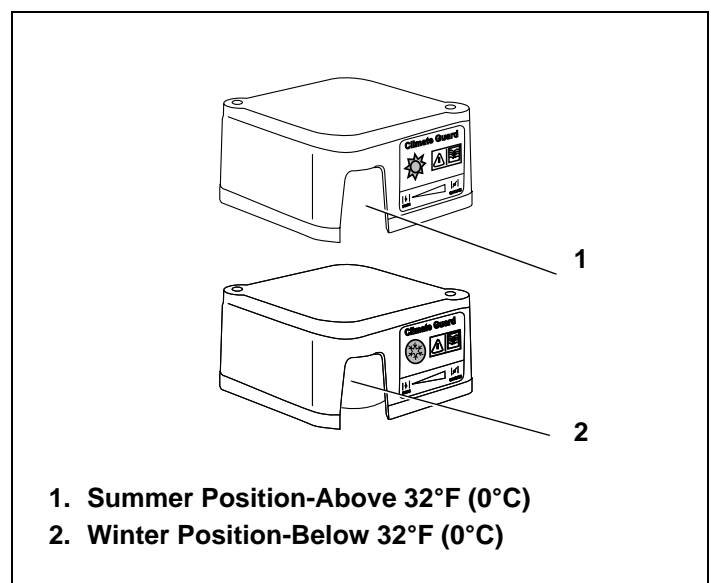

Figure 34. Air Cleaner Cover Positions

## F. Alternator (Optional)

For alternator related electrical problems such as:

- Inoperative Starter
- Discharged Battery
- Fuse Replacement
- Alternator Maintenance/Repairs

See your equipment manufacturer's instructions and an Authorized TecumsehPower Servicing Dealer.

## G. Carburetor

If you think your carburetor needs adjusting, see your nearest Authorized TecumsehPower Servicing Dealer. Engine performance should not be affected at altitudes up to 7,000 feet (2,134 meters). For operation at higher elevations, contact an Authorized TecumsehPower Servicing Dealer.

## H. Engine Speed

 **WARNING** To avoid serious injury or death, DO NOT modify engine in any way.

Tampering with the governor setting can lead to a runaway engine and cause it to operate at unsafe speeds. NEVER tamper with factory setting of engine governor.

Running the engine faster than the speed set at the factory can be dangerous and will **VOID THE ENGINE WARRANTY.**

## I. Adjustments

DO NOT make any engine adjustments. Factory settings are satisfactory for most conditions. If adjustments are needed, contact your Authorized TecumsehPower Servicing Dealer.

## VIII. Transporting Your Engine

 **WARNING** NEVER transport this engine inside another vehicle or in any enclosed space if there is any gasoline in the tank. Fuel vapor or spilled fuel may ignite leading to serious injury or death.

If there is fuel in the fuel tank, close the fuel shut-off valve, if equipped, and transport the engine upright in an open vehicle, such as an open trailer or open bed of a pickup truck.

If you DO NOT have an open vehicle and have to transport the engine upright in a closed vehicle, follow these steps for emptying the fuel tank before transporting:

1. Empty fuel tank by using a commercially available suction device designed for use with gasoline.

 **WARNING** To avoid serious injury or death, DO NOT pour fuel from engine or siphon fuel by mouth.

2. Drain fuel into an approved red GASOLINE container, being careful to avoid spilling.
3. Run the engine until remaining fuel is consumed.

 **WARNING** NEVER leave the engine unattended when it is running and NEVER run engine in enclosed areas to avoid death or serious injury.

## IX. Storing Your Engine

### A. Short-Term/Seasonal Storage

#### I. Clean Engine

Before servicing the engine remove the carburetor cover and/or blower housing. Remove grass clippings, dirt and debris from the following areas:

- Cooling Fins
- Air Intake Screen
- Levers
- Linkage Area
- Guards
- Carburetor
- Head

Removing debris will insure adequate cooling, correct engine speed and reduce the risk of fire.

#### II. Fuel Storage

 **WARNING** NEVER store engine with fuel in the fuel tank inside a building with potential sources of ignition such as hot water or space heaters, clothes dryers, electric motors, etc. Doing so may lead to an explosion resulting in death or serious injury.

##### NOTES

*If engine fuel stored in the gas tank and/or an approved gas container is to be unused without gasoline stabilizer for more than 15-30 days, prepare it for short-term/seasonal storage. See "IV. Fuel Treatment" instructions. Afterward, continue reading instructions below.*

*If engine fuel is to be stored for more than one season, without gasoline stabilizer, it will gradually deteriorate. Also, if it is stored in the engine's gas tank without gasoline stabilizer it is likely that your carburetor will have gum deposits, a clogged fuel system and **WILL VOID YOUR WARRANTY**. Prepare the fuel for extended storage. See "B. Extended Storage" instructions. Afterward, continue reading instructions below.*

#### III. Fuel System

To avoid stale gas and carburetor problems, treat the fuel system in the following method below:

##### NOTES

*TecumsehPower Company recommends using ULTRA-FRESH™ Gasoline Stabilizer as an acceptable method of minimizing formation of fuel gum deposits during storage. This product is available from your Authorized TecumsehPower Servicing Dealer.*

*Always follow mix ratio found on stabilizer container. Failure to do so may result in equipment damage.*

*It is NOT necessary to drain stabilized gas from carburetor.*

## IV. Fuel Treatment

1. Add fuel stabilizer according to manufacturer's instructions.
2. Run engine at least 10 minutes after adding stabilizer to allow it to reach carburetor.

 **WARNING** NEVER store engine with fuel in the fuel tank inside a building with potential sources of ignition such as hot water or space heaters, clothes dryers, electric motors, etc. Doing so may lead to an explosion resulting in death or serious injury.

##### NOTE

*Instead of using a fuel preservative/stabilizer, you can empty the fuel tank as described under "I. Draining Fuel" instructions.*

### B. Extended Storage

#### I. Draining Fuel

##### NOTES

*Clean debris from engine before draining fuel from carburetor. See "I. Clean Engine" instructions. Afterward, continue reading instructions below.*

*If you have prepared your fuel for short-term storage it is NOT necessary to drain fuel that contains stabilizer from your carburetor. See "A. Short-Term/Seasonal Storage" instructions. Afterward, continue reading instructions below.*

 **WARNING** To avoid serious injury or death, DO NOT pour fuel from engine or siphon fuel by mouth.

1. To prevent serious injury from fuel fires, empty fuel tank by running engine until it stops from lack of fuel. DO NOT attempt to pour fuel from engine.
2. Run the engine while waiting until the remaining fuel is consumed.

 **WARNING** NEVER leave the engine unattended when it is running and NEVER run engine in enclosed areas to avoid death or serious injury.

3. Begin servicing the cylinder bore. See "II. Oil Cylinder Bore" instructions on page 18.

##### NOTE

*If you operate the engine during all four seasons, it is not necessary to lubricate the cylinder bore.*

## II. Oil Cylinder Bore

**CAUTION** When lubricating cylinder bore, fuel may spray from spark plug hole. To prevent serious injury from fuel fires, follow these instructions:

1. Carefully disconnect spark plug wire and keep it away from spark plug. See Figures 35 and 36.
  - Keep the disconnected spark plug wire securely away from metal parts where arcing could occur.
  - Carefully attach the spark plug wire to the grounding post, if provided.
  - Disconnect battery at negative terminal first, if engine is equipped with a DC electric starter.
  - Turn all engine switches to “OFF” position.
  - Remove ignition key, if provided.
2. Remove spark plug.
3. Squirt 1oz. (30 ml) of clean engine oil into spark plug hole.
4. Cover spark plug hole with rag to prevent fuel from spraying from spark plug hole when starter rope is pulled.

### NOTES

*For engines equipped with recoil starters proceed to Step 5.*

*For engines equipped with electric starters proceed to Step 6.*

5. Grasp starter cord handle:
  - a. Pull starter cord handle out slowly using a full arm stroke.
  - b. Repeat once. (This will distribute oil throughout the cylinder to prevent corrosion during storage.)
  - c. Proceed to Step 8.
6. Push starter button or turn ignition switch key to “START” position (see equipment manufacturer’s instructions) to cycle the engine for one to two seconds.
7. Turn ignition switch key to “OFF” position. Repeat Steps 6 and 7. (This will distribute oil throughout the cylinder to prevent corrosion during storage.)
8. Remove rag covering spark plug hole.
9. Install spark plug.
10. Carefully disconnect spark plug wire from grounding post, if provided. See Figure 36.
11. Connect spark plug wire to spark plug before attempting to start engine.

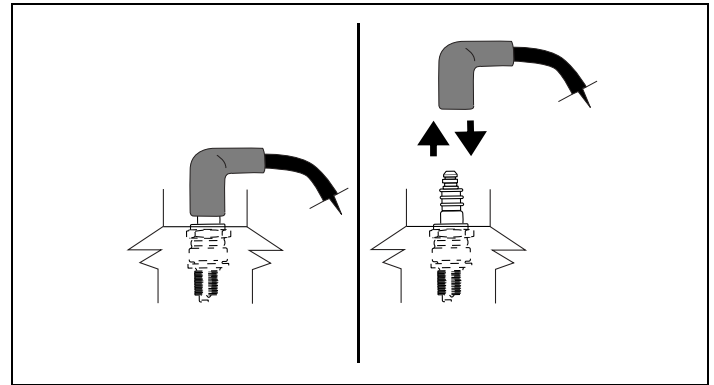

**Figure 35. Disconnecting/Connecting Spark Plug**

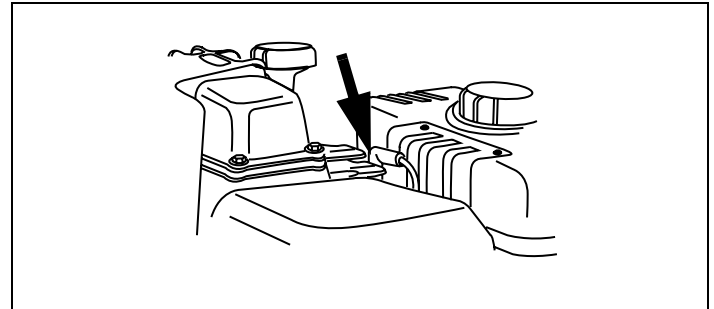

**Figure 36. Typical Spark Plug Connection**

## III. Oil

Change oil if NOT changed within the last 3 months. See “A. Checking and Changing Oil” instructions on page 13.

## IV. Battery

See equipment manufacturer’s instructions for proper battery storage if machine is equipped with a battery.

## X. Preventing Forest, Brush and Grass Fires

Local, state and federal laws may require use of a spark arrester to prevent fires. For example, it is a violation of California Public Resources Code (section 4442) to use or operate engine on any forest-covered, brush-covered or unimproved grass-covered land unless engine is equipped with a spark arrester. Spark arrester must be maintained in effective working order by owner and/or operator.

To determine if your engine has a spark arrester, locate the muffler on your engine. For example, the muffler discharge will have a spark arrester cover that reads “Screen Type 36085”.

If your engine does NOT have a spark arrester, you may purchase one from your Authorized TecumsehPower Servicing Dealer. In some cases the muffler may need to be replaced to allow the spark arrester to be installed.

# XI. Maintenance Intervals

Maintenance is one of the most important things that you can do to extend the life of your TecumsehPower engine. If you are unable to perform maintenance intervals yourself, contact your nearest Authorized TecumsehPower Servicing Dealer. Find them on our website at [www.TecumsehPower.com](http://www.TecumsehPower.com) or call TecumsehPower Company at 1-800-558-5402 for additional information. ALWAYS promptly follow maintenance intervals listed in this manual. See Table 3.

**Table 3. Maintenance Intervals**

Procedure	Time
Change Oil	After First 2 Hours When Engine is Warm
Check Oil Level	Every 5 Hours or Before Each Use
Clean Cooling Fins	Every 5 Hours or Before Each Use
Clean Foam Pre-Filter	Every 25 Hours or 3 Months
Change Oil	Every 50 Hours or 3 Months
Replace Paper Filter	Every 100 Hours or Seasonally
Check Spark Plug	Every 100 Hours or Seasonally
Replace Spark Plug	Every 200 Hours or Seasonally

## Scheduled Maintenance

### After First 2 Hours When Engine is Warm

#### 1. Change Oil

Date \_\_\_\_\_ Owner/Dealer

### Every 5 Hours or Before Each Use

#### 1. Check Oil Level

#### 2. Clean Cooling Fins

Date \_\_\_\_\_ Owner/Dealer

Date \_\_\_\_\_ Owner/Dealer

Date \_\_\_\_\_ Owner/Dealer

Date \_\_\_\_\_ Owner/Dealer

Date \_\_\_\_\_ Owner/Dealer

Date \_\_\_\_\_ Owner/Dealer

Date \_\_\_\_\_ Owner/Dealer

Date \_\_\_\_\_ Owner/Dealer

Date \_\_\_\_\_ Owner/Dealer

Date \_\_\_\_\_ Owner/Dealer

Date \_\_\_\_\_ Owner/Dealer

Date \_\_\_\_\_ Owner/Dealer

Date \_\_\_\_\_ Owner/Dealer

### Every 25 Hours or 3 Months

#### 1. Clean Foam Pre-Filter

Date \_\_\_\_\_ Owner/Dealer

Date \_\_\_\_\_ Owner/Dealer

Date \_\_\_\_\_ Owner/Dealer

Date \_\_\_\_\_ Owner/Dealer

Date \_\_\_\_\_ Owner/Dealer

Date \_\_\_\_\_ Owner/Dealer

Date \_\_\_\_\_ Owner/Dealer

Date \_\_\_\_\_ Owner/Dealer

Date \_\_\_\_\_ Owner/Dealer

### Every 50 Hours or 3 Months

#### 1. Change Oil

Date \_\_\_\_\_ Owner/Dealer

Date \_\_\_\_\_ Owner/Dealer

Date \_\_\_\_\_ Owner/Dealer

Date \_\_\_\_\_ Owner/Dealer

Date \_\_\_\_\_ Owner/Dealer

Date \_\_\_\_\_ Owner/Dealer

Date \_\_\_\_\_ Owner/Dealer

Date \_\_\_\_\_ Owner/Dealer

Date \_\_\_\_\_ Owner/Dealer

Date \_\_\_\_\_ Owner/Dealer

Date \_\_\_\_\_ Owner/Dealer

### Every 100 Hours or Seasonally

#### 1. Replace Paper Filter

#### 2. Check Spark Plug

Date \_\_\_\_\_ Owner/Dealer

Date \_\_\_\_\_ Owner/Dealer

Date \_\_\_\_\_ Owner/Dealer

Date \_\_\_\_\_ Owner/Dealer

Date \_\_\_\_\_ Owner/Dealer

Date \_\_\_\_\_ Owner/Dealer

Date \_\_\_\_\_ Owner/Dealer

Date \_\_\_\_\_ Owner/Dealer

Date \_\_\_\_\_ Owner/Dealer

### Every 200 Hours or Seasonally

#### 1. Replace Spark Plug

Date \_\_\_\_\_ Owner/Dealer

Date \_\_\_\_\_ Owner/Dealer

Date \_\_\_\_\_ Owner/Dealer

Date \_\_\_\_\_ Owner/Dealer

Date \_\_\_\_\_ Owner/Dealer

Date \_\_\_\_\_ Owner/Dealer

Date \_\_\_\_\_ Owner/Dealer

Date \_\_\_\_\_ Owner/Dealer

Date \_\_\_\_\_ Owner/Dealer

Date \_\_\_\_\_ Owner/Dealer

# CALIFORNIA & US EPA EMISSION CONTROL WARRANTY STATEMENT

The U. S. Environmental Protection Agency ("EPA"), the California Air Resources Board ("CARB") and TecumsehPower Company are pleased to explain the Federal and California Emission Control Systems Warranty on your new small off-road engine. In California, new 1995 and later small off-road engines must be designed, built and equipped to meet the State's stringent anti-smog standards. In other states, new 1997 and later model year engines must be designed, built and equipped, at the time of sale, to meet the U.S. EPA regulations for small non-road engines. TecumsehPower Company will warrant the emission control system on your small off-road engine for the periods of time listed below, provided there has been no abuse, neglect, unapproved modification, or improper maintenance of your small off-road engine.

Your emission control system may include parts such as the carburetor, air cleaner assembly, ignition system, exhaust system, crankcase breather assembly and, the evaporative control system. Also included may be the compression release system and other emission-related assemblies.

Where a warrantable condition exists, TecumsehPower Company will repair your small off-road engine at no cost to you for diagnosis, parts and labor.

## MANUFACTURER'S EMISSION CONTROL SYSTEM WARRANTY COVERAGE

Emission control systems on 1995 and later model year California small off-road engines are warranted for two years as hereinafter noted. In other states, 1997 and later model year engines are also warranted for two years. If, during such warranty period, any emission-related part on your engine is defective in materials or workmanship, the part will be repaired or replaced by TecumsehPower Company.

## OWNER'S WARRANTY RESPONSIBILITIES

As the small off-road engine owner, you are responsible for the performance of the required maintenance listed in your Operator's Manual, but TecumsehPower Company will not deny warranty solely due to the lack of receipts or for your failure to provide written evidence of the performance of all scheduled maintenance.

As the small off-road engine owner, you should, however, be aware that TecumsehPower Company may deny you warranty coverage if your small off-road engine or a part thereof has failed due to abuse, neglect, improper maintenance or unapproved modifications.

You are responsible for presenting your small off-road engine to a TecumsehPower Authorized Service Outlet

(any TecumsehPower Registered Service Dealer, TecumsehPower Authorized Service Distributor or TecumsehPower Central Warehouse Distributor) as soon as a problem exists. The warranty repairs should be completed in a reasonable amount of time, not to exceed 30 days.

Warranty service can be arranged by contacting either an Authorized TecumsehPower Servicing Dealer and/or TecumsehPower Company, c/o Service Manager, 900 North Street, Grafton, WI 53024-1499. Telephone 1-262-377-2700 [or in USA/Canada call 1-800-558-5402].

## IMPORTANT NOTE

This warranty statement explains your rights and obligations under the Emission Control System Warranty ("ECS Warranty") which is provided to you by TecumsehPower Company pursuant to California law. TecumsehPower Company also provides to original purchasers of new TecumsehPower engines the TecumsehPower Company Limited Warranties for New TecumsehPower Engines and Electronic Ignition Modules. The TecumsehPower Company Limited Warranties for New TecumsehPower Engines and Electronic Ignition Modules ("TecumsehPower Company Warranty") are located on the back cover of the Operator's Manual, enclosed with all new TecumsehPower engines. The ECS Warranty applies only to the emission control system of your new engine. To the extent that there is any conflict in terms between the ECS Warranty and the TecumsehPower Company Warranty, the ECS Warranty shall apply except in any circumstances in which the TecumsehPower Company Warranty may provide a longer warranty period. Both the ECS Warranty and the TecumsehPower Company Warranty describe important rights and obligations with respect to your new engine.

Warranty service can only be performed by a TecumsehPower Authorized Servicing Dealer. At the time of requesting warranty service, evidence must be presented of the date of sale to the original purchaser. The purchaser shall pay any charges for making service calls and/or for transporting the products to and from the place where the inspection and/or warranty work is performed. The purchaser shall be responsible for any damage or loss incurred in connection with the transportation of any engine or any part(s) thereof submitted for inspection and/or warranty work.

If you have any questions regarding your warranty rights and responsibilities, you should contact TecumsehPower Company at 1-262-377-2700 or in USA/Canada call 1-800-558-5402.

Revised February 2008

## IMPORTANT!

The Emission Regulations may be different for your country. The Emissions Control Warranty Statement is only applicable to engines with an emissions compliance statement and decal that references "Emissions Regulations".

## EMISSION CONTROL SYSTEM WARRANTY

Emission Control System Warranty ("ECS Warranty") for 1995 and later model year California small off-road engines (for other states, 1997 and later model year engines):

**A. APPLICABILITY:** This warranty shall apply to 1995 and later model year California small off-road engines (for other states, 1997 and later model year engines). The ECS Warranty Period shall begin on the date the new engine or equipment is delivered to its original, end-use purchaser, and shall continue for 24 consecutive months thereafter.

**B. GENERAL EMISSIONS WARRANTY COVERAGE:**

TecumsehPower Company warrants to the original, end-use purchaser of the new engine or equipment and to each subsequent purchaser that each of its small off-road engines is:

1. Designed, built and equipped so as to conform with all applicable regulations adopted by the Air Resources Board pursuant to its authority in Chapters 1 and 2, Part 5, Division 26 of the Health and Safety Code, and
2. Free from defects in materials and workmanship which, at any time during the ECS Warranty Period, will cause a warranted emissions-related part to fail to be identical in all material respects to the part as described in the engine manufacturer's application for certification.

**C. THE ECS WARRANTY ONLY PERTAINS TO EMISSION-RELATED PARTS ON YOUR ENGINE AS FOLLOWS:**

1. Any warranted, emissions-related parts which are not scheduled for replacement as required maintenance in the Operator's Manual shall be warranted for the ECS Warranty Period. If any such part fails during the ECS Warranty Period, it shall be repaired or replaced by TecumsehPower Company according to Subsection 4 below. Any such part repaired or replaced under the ECS Warranty shall be warranted for any remainder of the ECS Warranty Period.
2. Any warranted, emissions-related part which is scheduled only for regular inspection as specified in the Operator's Manual shall be warranted for the ECS Warranty Period. A statement in such written instructions to the effect of "repair or replace as necessary", shall not reduce the ECS Warranty Period. Any such part repaired or replaced under the ECS Warranty shall be warranted for the remainder of the ECS Warranty Period.
3. Any warranted, emissions-related part which is scheduled for replacement as required maintenance in the Operator's Manual, shall be warranted for the period of time prior to the first scheduled replacement point for that part. If the part fails prior to the first scheduled replacement, the part shall be repaired or replaced by TecumsehPower Company according to Subsection 4 below. Any such emissions-related part repaired or replaced under the ECS Warranty, shall be warranted for the remainder of the ECS Warranty Period prior to the first scheduled replacement point for such emissions-related part.
4. Repair or replacement of any warranted, emissions-related part under this ECS Warranty shall be performed at no charge to the owner at a TecumsehPower Authorized Service Outlet.

5. The owner shall not be charged for diagnostic labor which leads to the determination that a part covered by the ECS Warranty is in fact defective, provided that such diagnostic work is performed at a TecumsehPower Authorized Service Outlet.
6. TecumsehPower Company shall be liable for damages to other original engine components or approved modifications proximately caused by a failure under warranty of an emission-related part covered by the ECS Warranty.
7. Throughout the ECS Warranty Period, TecumsehPower Company shall maintain a supply of warranted emission-related parts sufficient to meet the expected demand for such emission-related parts.
8. Any TecumsehPower Company authorized and approved emission-related replacement part may be used in the performance of any ECS Warranty maintenance or repair and will be provided without charge to the owner. Such use shall not reduce TecumsehPower Company ECS Warranty obligations.
9. Unapproved add-on or modified parts may not be used to modify or repair a TecumsehPower engine. Such use voids this ECS Warranty and shall be sufficient grounds for disallowing an ECS Warranty claim. TecumsehPower Company shall not be liable hereunder for failures of any warranted parts of a TecumsehPower engine caused by the use of such an unapproved add-on or modified part.

**EMISSION-RELATED PARTS INCLUDE THE FOLLOWING:**

1. Carburetor Assembly including internal components:
  - a) Carburetor gaskets
  - b) Intake pipe
2. Air Cleaner Assembly including components:
  - a) Air filter element
3. Ignition System including components:
  - a) Spark plug
  - b) Ignition module
  - c) Flywheel assembly
4. Exhaust System including components:
  - a) Catalytic muffler (*if so equipped*)
  - b) Muffler gasket (*if so equipped*)
  - c) Exhaust manifold (*if so equipped*)
5. Crankcase Breather Assembly including components
  - a) Breather connection tube
6. Evaporative Control System including components:
  - a) Fuel line(s)
  - b) Fuel filter
  - c) Canister (*if so equipped*)
  - d) Fuel tank (*if so equipped*)
  - e) Fuel fill cap (*if so equipped*)

Revised February 2008

### IMPORTANT!

The Emission Regulations may be different for your country. The Emissions Control Warranty Statement is only applicable to engines with an emissions compliance statement and decal that references "Emissions Regulations".

## XII. Warranty Information

### LIMITED WARRANTY FOR NEW TECUMSEHPower ENGINES AND ELECTRONIC IGNITION MODULES

For the time period shown below from the date of purchase and subject to the exceptions and limitations described herein, TecumsehPower Company will, at its option as the exclusive remedy, either repair or replace for the original purchaser, free of charge, any part of any new TecumsehPower engine which is found, upon examination by any Authorized TecumsehPower Servicing Outlet or by TecumsehPower's Service Division, to be **DEFECTIVE IN MATERIAL AND/OR WORKMANSHIP**. This Limited Warranty **DOES NOT COVER** (i) any TecumsehPower engine or part(s) thereof used to power any vehicle in competitive racing and/or used on any commercial or rental track, or (ii) defects or damage caused by alterations or modifications of new TecumsehPower engines or parts or by normal wear, accidents, improper maintenance, improper use or abuse of the product, or failure to follow the instructions contained in an Instruction Manual for the operation of the new TecumsehPower engine or part. The cost of normal maintenance or replacement of service items which are not defective shall be paid for by the original purchaser. At the time warranty service is requested, evidence must be presented of the date of purchase by the original purchaser. Any charge for making service calls and/or for transporting any engine or part(s) thereof to and from the place where the inspection and/or warranty work is performed is payable solely by the purchaser. The purchaser is responsible for any damage or loss incurred in connection with the transportation of any engine or part(s) thereof submitted for inspection and/or warranty work. **WARRANTY SERVICE CAN ONLY BE PERFORMED BY A TECUMSEHPower AUTHORIZED SERVICE OUTLET.** Warranty service can be arranged by contacting a TecumsehPower Authorized Service Outlet (any TecumsehPower Registered Service Dealer, TecumsehPower Authorized Service Distributor, or TecumsehPower Central Warehouse Distributor) or by contacting TecumsehPower Company c/o Service Manager, 900 North Street, Grafton, Wisconsin USA 53024-1499.

Warranty	"CONSUMER USE" (4)		"COMMERCIAL USE" (5)	
	Within	Outside	Within	Outside
Category (6)	U.S.A. and Canada	U.S.A. and Canada	U.S.A. and Canada	U.S.A. and Canada
(A)	90 Day	90 Day (1)	No Warranty	No Warranty
(B)	1 Year	1 Year (1)	1 Year	1 Year
(C)	2 Years	1 Year (1)	1 Year	1 Year
(D)	2 Years	2 Years (2)	1 Year	1 Year
(E)	2 Years	2 Years	1 Year	1 Year
(H)	2 'n 10 (3)	2 'n 10 (3)	1 Year	1 Year
(K)	2 'n 10 (3)	2 'n 10 (3)	2 'n 10 (3)	1 Year
(M) (7)	3 Years	3 Years	1 Year	1 Year

- (1) 2 years for Member States of the European Union. Consumers may have additional legal rights not affected by the terms of this warranty pursuant to EU Directive 1999/44/EC and the national legislation of certain Member States of the European Union.
- (2) 1 year for Australian/New Zealand for rotary mower engines.
- (3) 2 years on engine and 10 years (the first 5 years covering parts and labor only; the second 5 years covering parts only) on electronic ignition.
- (4) For purposes of this warranty policy, "consumer use" shall mean consumer's personal, residential, household use by the original retail purchaser.
- (5) For purposes of this warranty policy, "commercial use" shall mean all other uses, including use for commercial, income producing, or rental purposes.
- (6) The engine warranty category of your engine can be determined by review of the engine model number on the "Important Engine Information" decal. One letter in the engine model number will be surrounded by parenthesis (A), (B), (C), (D), (E), (H) (K) or (M) and that letter is your engine warranty category designation.
- (7) Qualification for three (3) year consumer use warranty under engine warranty category (M) may be determined by notation of an (M) designation on the "Important Engine Information" decal located on the engine housing or an addendum decal affixed adjacent thereto.

THIS EXPRESS WARRANTY IS SUPPLEMENTED BY THE TECUMSEHPower CALIFORNIA EMISSION CONTROL WARRANTY STATEMENT, if any.

**THIS EXPRESS WARRANTY IS IN LIEU OF ALL OTHER EXPRESS WARRANTIES.** Neither TecumsehPower Company nor any of its affiliates makes any warranties, representations, or promises, written or oral, as to the quality of the engine or any of its parts, other than as set forth herein. **ANY IMPLIED WARRANTY OF MARKETABILITY, MERCHANTABILITY, OR FITNESS FOR A PARTICULAR PURPOSE, TO THE EXTENT THAT EITHER MAY APPLY TO ANY TECUMSEHPower ENGINE OR PART(S) THEREOF, SHALL BE LIMITED IN DURATION TO THE PERIODS OF THE EXPRESS WARRANTIES SHOWN IN THE WARRANTY PERIOD CHART ABOVE AND TO THE EXTENT PERMITTED BY LAW ANY AND ALL IMPLIED WARRANTIES ARE EXCLUDED. IN NO EVENT WILL TECUMSEHPower COMPANY BE LIABLE FOR ANY INDIRECT, INCIDENTAL, CONSEQUENTIAL OR SPECIAL DAMAGES AND/OR EXPENSES, INCLUDING, BUT NOT LIMITED TO, ANY LOSS OF TIME, INCONVENIENCE, LOSS OF UNIT USE OR ANY COST OR EXPENSE OF SUBSTITUTE UNITS DURING PERIODS OF MALFUNCTION OR NON-USE.** Some states do not allow limitations on how long an implied warranty lasts or the exclusion or limitation of incidental or consequential damages, so the above limitation(s) or exclusion(s) may not apply to you. This Limited Warranty gives you specific legal rights and you may also have other legal rights which vary from state-to-state.

TecumsehPower Company neither assumes nor authorizes any other person, natural or corporate, to assume for TecumsehPower Company any other obligations or liabilities in connection with or with respect to any TecumsehPower product or parts. The seller or dealer of a TecumsehPower product or part has no authority, whatsoever, to make any representations or promises on behalf of TecumsehPower Company or to modify the terms or limitations of TecumsehPower's warranty in any way.

Revised February 2008

#### **WARNING** CALIFORNIA PROPOSITION 65

The engine exhaust from this product contains chemicals known to the State of California to cause cancer, birth defects or other reproductive harm.



TecumsehPower Company • Grafton, Wisconsin 53024-1499 • USA  
Telephone: 1-800-558-5402

Visit us at: [www.TecumsehPower.com](http://www.TecumsehPower.com)

**181-719-14**  
**(English) 6/01/08**