

10 HP INTEK™ PRO Model Series 206400

Displacement 18.6 cu. in. (305 cc)

Bore 3.12 in. (79 mm)

Stroke 2.43 in. (61 mm)

Oil Capacity 28 fl. oz. (0.82 l)



Features:

- Dura-Bore™ cast iron cylinder sleeve for extended life
- Maintenance-free Magnetron® electronic ignition for quick, dependable starts
- Dual-Clean™ air cleaner pleated paper filter with a foam pre-cleaner ensures maximum protection for extended engine life
- Low oil sensor device
- Overhead valve design (OHV) for cooler operation and longer valve life
- Extended oil fill
- Buyer protection package provides two-year consumer engine warranty

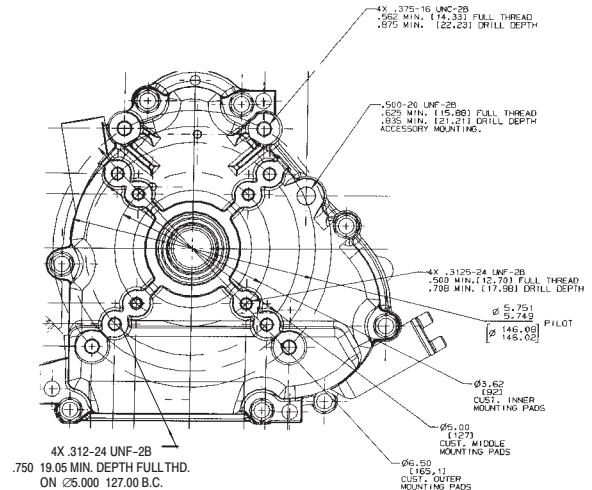
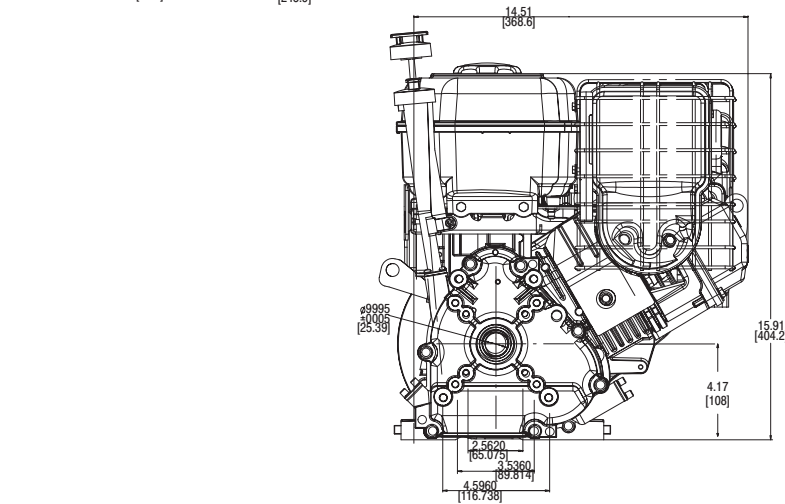
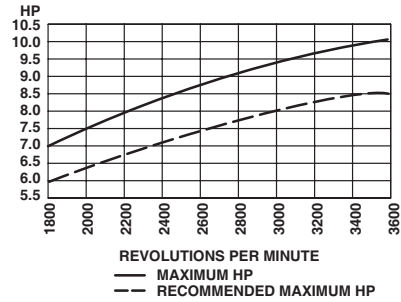
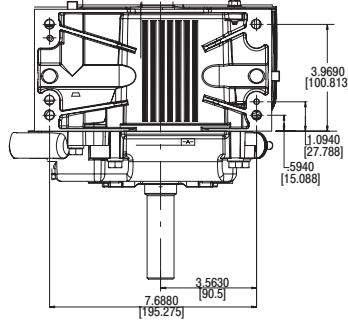
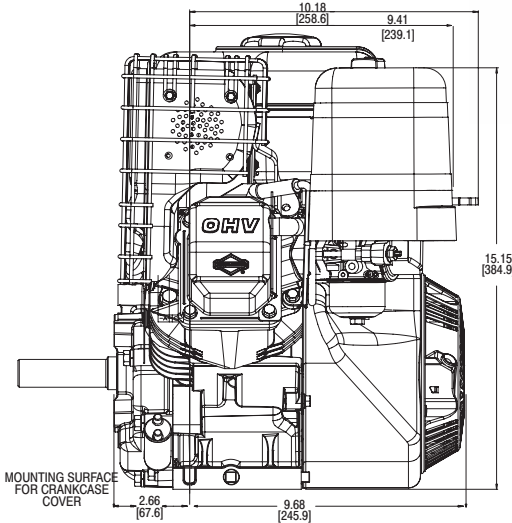

To make the center line of crankshaft the same as 190000 and 250000 Model Series, order 695154 spacer kit.

Model Type	Shipping Weight	Crankshaft	Crankshaft (P.T.O.) Extension	Dimension	Starter Position	Bolt-On/Changeable	Governor	Controls	Flange Mtg.	Manual Choke	Remote Stop Switch	Low Oil Sensor	Fuel Tank (Quarts)	Top Governor Speed	Notes
206432															
0035	54	695818	Threaded 1-14, 1" tapped length	3-21/32(c)	10:30	M	AG/R/MF	X X X X	X X X X	X	4	3600	•		
0036	54	695462	1" dia., Keyway, tapped 7/16-20	3-21/32(c)	10:30	M	AG/R/MF	X X X X	X X X X	X	4	3600	•		
206437															
0041	75	695462	1" dia., Keyway, tapped 7/16-20	3-21/32(c)	10:30	M	AG/R/MF	X X X X	X X X X	X	4	3600	◆◆		
206452															
0049	67	695817	6 to 1 gear reduction ccw rotation gear shaft, 1" dia Keyway	2-29/32(a)	10:30	M	AG/R/MF		X X X X	X	4	3600			

• Ball bearing PTO, DU magneto side.

◆ Engine equipped with 12 Volt Gear Drive Starter and 10 Amp DC Alternator with Starter Panel Assembly.