

# 15.50 Gross Torque 342 CC

Bore 3.30 in. (83.8 mm)

Stroke 2.44 in. (61.9 mm)

Oil Capacity 26-28 fl. oz. (0.77 - 0.83 L)



## Features:

- Dura-Bore™ Cast iron cylinder sleeve for extended life
- Maintenance-free Magnetron® electronic ignition for quick, dependable starts
- Overhead valve design (OHV) for cooler operation and longer valve life
- Duel-Clean™ air cleaner pleated paper filter with a foam pre-cleaner ensures maximum protection for extended engine life
- Buyer protection package provides two-year consumer engine warranty

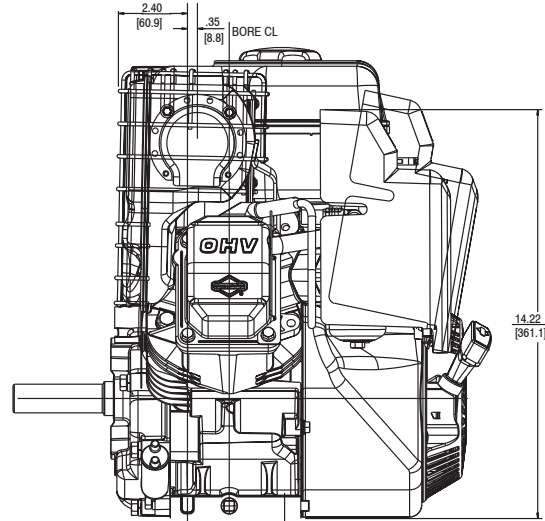
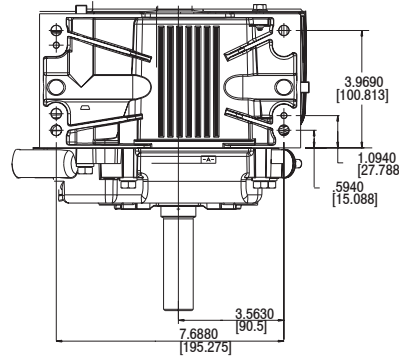
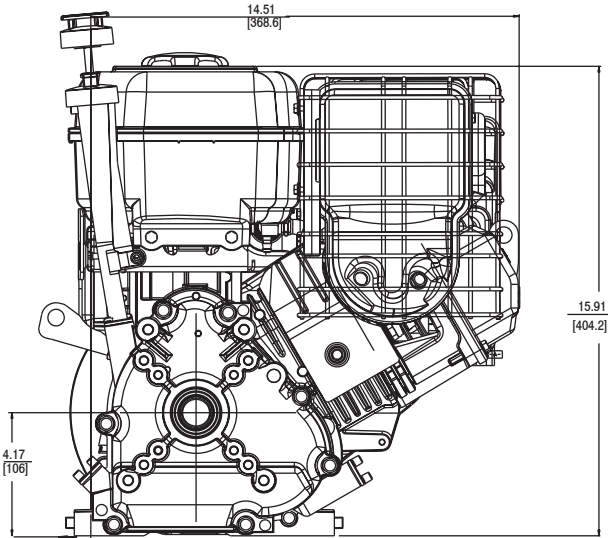

To make the center line of crankshaft the same as 190000 and 250000 Model Series, order 695154 spacer kit.

Model Type	Shipping Weight	Crankshaft	Crankshaft (P.T.O.) Extension	Dimension	Starter Position Bolt-On/Changeable	Governor	Controls	Flange Mtg.	Manual Choke	Remote Stop Switch	Fuel Tank (Quarts)	Top Governor Speed	Notes
212412													
0570		694678	Tapered, tapped 5/16-24	4-11/32(c)	1:30	M	FC	X	X	X	*	3750	
212432													
0536	62	695462	1" dia., Keyway, tapped 7/16-20	3-21/32(c)	10:30	M	AG/R/MF	X	X	X	4	3600	•
212437													
0541	70	695369	1" dia., Keyway, tapped 3/8-24	2-29/32(c)	10:30	M	AG/R/MF	X	X	X	4	3600	•

• Ball bearing PTO \* Fuel Tank Omitted