

Vanguard™ 11.0 Gross HP 391 CC

Bore 3.5 in. (89 mm)

Stroke 2.48 in. (63 mm)

Oil Capacity 32 fl. oz. (.95 L)



Features:

- Dura-Bore™ cast iron cylinder sleeve for extended life
- Maintenance-free Magnetron® electronic ignition for quick, dependable starts
- Dual-Clean™ air cleaner pleated paper filter with a foam pre-cleaner ensures maximum protection for extended engine life
- Oil Gard low oil engine shutdown device
- Overhead valve design (OHV) for cooler operation and longer valve life
- Buyer protection package provides two-year commercial engine warranty

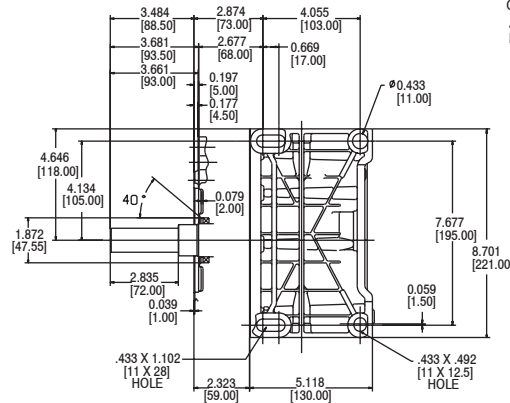
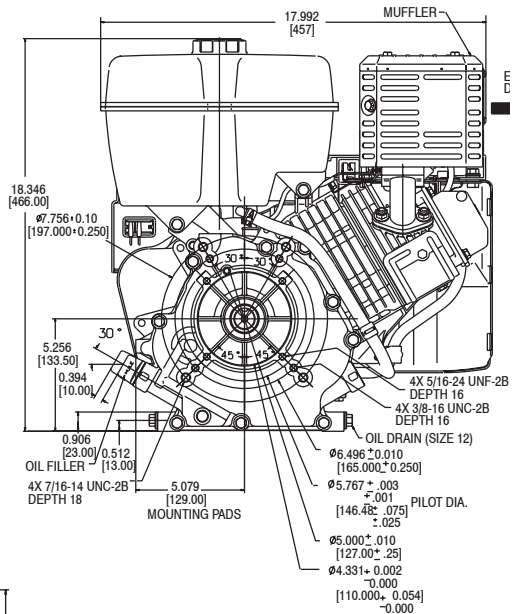
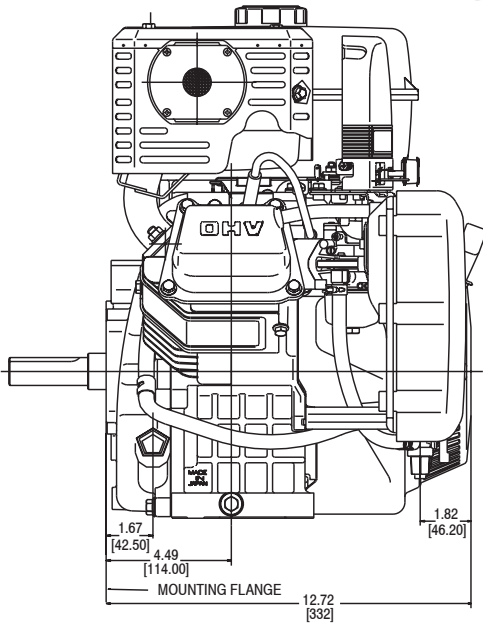

Model Type	Shipping Weight	Crankshaft	Crankshaft (P.T.O.) Extension	Dimension	Starter Position Bolt-On/Changeable	Governor	Controls	Flange Mtg.	Manual Choke	Rocker Stop Switch	Oil Gard	Fuel Tank (Quarts)	Top Governor Speed	Notes
235432														
0235	81	715342	1" dia., Keyway, tapped 7/16-20	3-31/64(c)	10:30	M	AG/R/MF	X	X	X	X	8.3	3600	•

• Ball bearing PTO and magneto side.