

23 HP VANGUARD™ Model Series 380400

Displacement 38.26 cu. in. (627 cc)

Bore 2.97 in. (75 mm)

Stroke 2.75 in. (70 mm)

Oil Capacity 48 fl. oz. (1.42 l) w/o Filter
56 fl. oz. (1.66 l) w/Filter



COMMERCIAL POWER



Features:

- Dura-Bore™ cast iron cylinder sleeve for extended life
- Float carburetor for consistent easy starting
- Maintenance-free Magnetron® electronic ignition for quick, dependable starts
- Dual-Clean™ air cleaner pleated paper filter with a foam pre-cleaner ensures maximum protection for extended engine life
- Full pressure lubrication with oil cooler and spin-on oil filter assures controlled lubrication for extended component life
- Overhead valve design (OHV) for cooler operation and longer valve life
- Buyer protection package provides two-year commercial engine warranty

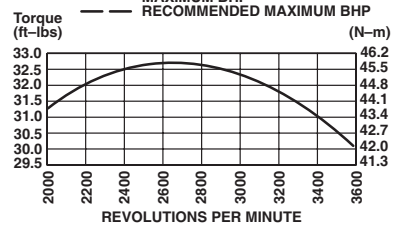
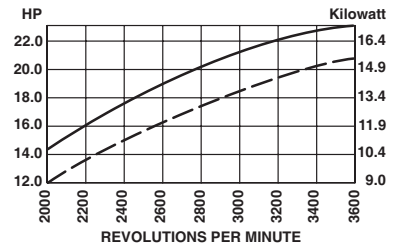
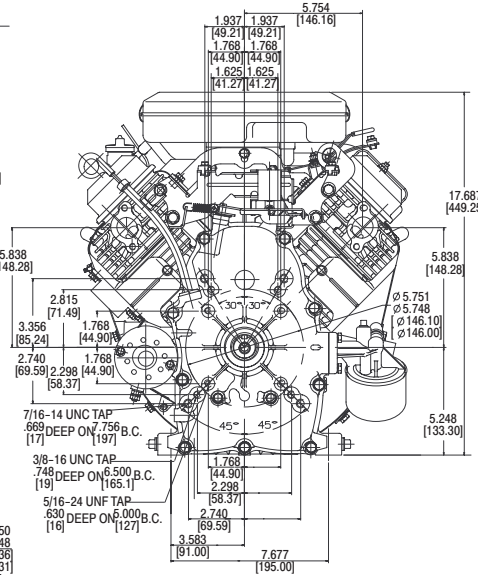
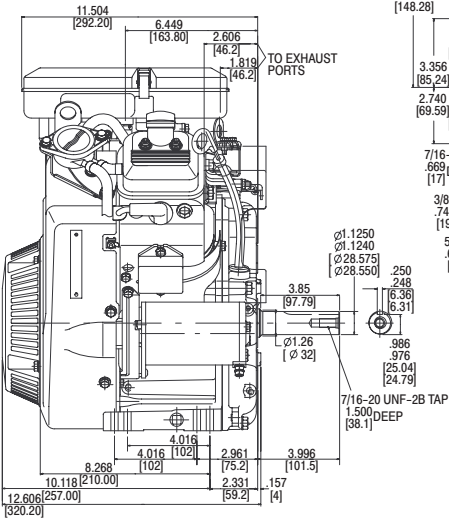
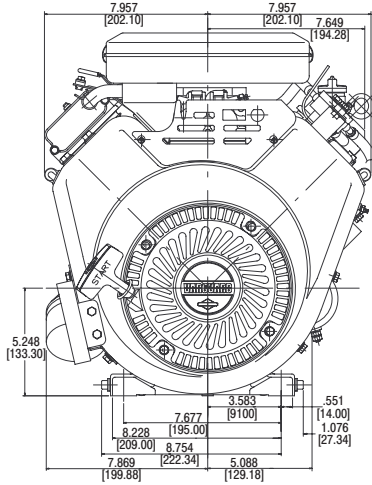

See Engine Accessories & Products Catalog Form MS-3880 for Exhaust Manifold and Muffler Options.

Model Type	Shipping Weight	Crankshaft	Crankshaft (P.T.O.) Extension	Dimension	Starter Position	Boil-On/Changeable	Oil Filler & Drain	Governor	Controls	Exhaust System	Fuel Tank (Quarts)	Pulse Fuel Pump	Flange Mtg.	Oil Pump w/Filter	Manual & Remote Choke	Top Governor Speed	Notes
380447																	
0048	87	691139	1-1/8" dia., Keyway, tapped 7/16-20	4 (c)	9	★	M	AG/R/MF	• ■	X	X	X	X	X	3600	◆	
0065	87	692171	1" dia., Keyway, tapped 3/8-24	2-29/32(c)	9	★	M	AG/R/MF	• ■	X	X	X	X	X	3600	◆	
0077	87	692170	Threaded 1-14, 1" thread length	3-21/32(c)	9	★	M	AG/R/MF	• ■	X	X	X	X	X	3600	◆	
0078	85	692173	Tapered, drill & tap 5/16-24	3-51/64(c)	9	★	M	AG	• ■	X	X	X			3750	◆	
0079	85	692171	1" dia., Keyway, tapped 3/8-24	2-29/32(c)		★	M	AG/R/MF	• ■	X	X	X	X	X	3600	◆	

• Exhaust manifold and muffler omitted. ★ Oil fill and dipstick in cover; dual drain. ■ Fuel tank omitted.
◆ Engine equipped with 12 Volt Gear Drive Starter and 16 Amp DC Alternator with Starter Panel Assembly.