

# 21 HP VANGUARD™ Model Series 381400

Displacement 38.26 cu. in. (627 cc)

Bore 2.97 in. (75 mm)

Stroke 2.75 in. (70 mm)

Oil Capacity 48 fl. oz. (1.42 l) w/o Filter  
56 fl. oz. (1.66 l) w/Filter



COMMERCIAL POWER



## Features:

- Dura-Bore™ cast iron cylinder sleeve for extended life
- Float carburetor for consistent easy starting
- Maintenance-free Magnetron® electronic ignition for quick, dependable starts
- Dual-Clean™ air cleaner pleated paper filter with a foam pre-cleaner ensures maximum protection for extended engine life
- Full pressure lubrication with oil cooler and spin-on oil filter assures controlled lubrication for extended component life
- Overhead valve design (OHV) for cooler operation and longer valve life
- Buyer protection package provides two-year commercial engine warranty

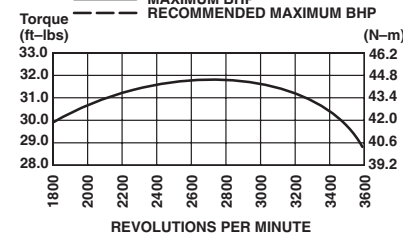
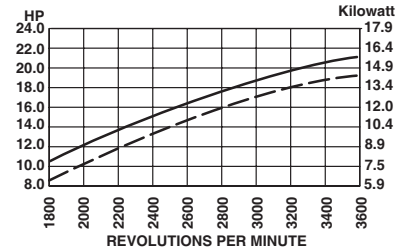
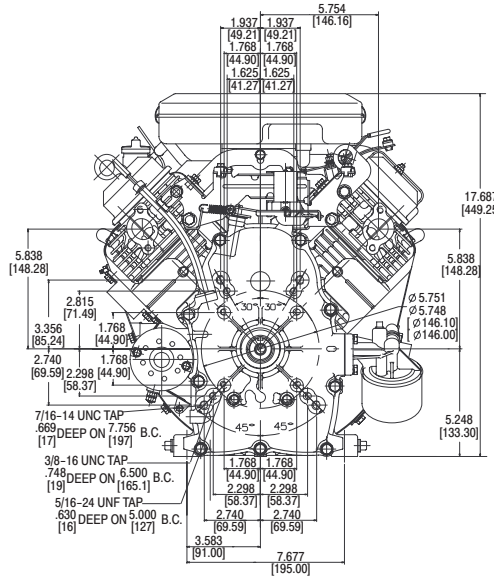
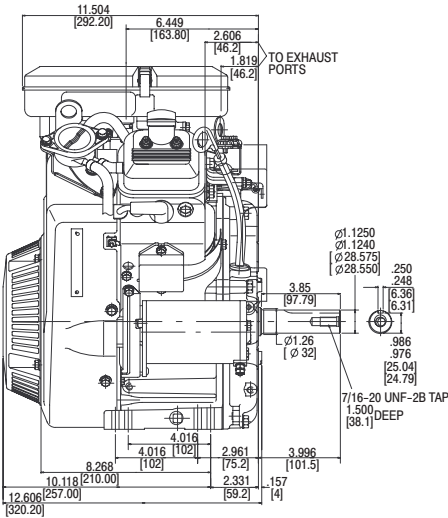
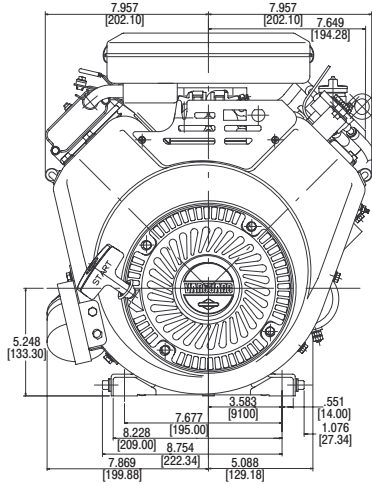

See Engine Accessories & Products Catalog Form MS-3880 for Exhaust Manifold and Muffler Options.

Model Type	Shipping Weight	Crankshaft	Crankshaft (P.T.O.) Extension	Dimension	Starter Position Bolt-On/Changeable	Oil Filler & Drain Governor	Controls	Exhaust System	Fuel Tank (Quarts)	Pulse Fuel Pump	Flange Mfg.	Oil Pump w/Filter	Manual & Remote Choke	Top Governor Speed	Notes	
381447																
0075	94	692171	1" dia., Keyway, tapped 3/8-24	2-29/32(c)	9	★	M	AG/R/MF	•	■	X	X	X	X	3600	◆

• Exhaust manifold and muffler omitted. ★ Oil fill and dipstick in cover; dual drain. ■ Fuel tank omitted.  
◆ Engine equipped with 12 Volt Gear Drive Starter and 16 Amp DC Alternator with Starter Panel Assembly.