

# Vanguard™ 31.0 Gross HP 895 CC

Bore 3.366 in. (85.5 mm)  
Stroke 3.071 in. (78.0 mm)  
Oil Capacity 79 fl. oz. (2.34 L)



## Features:

- Cast iron sleeve assures longer engine life and improved oil control
- Advanced Debris Management System allows the engine to run cleaner and cooler, which enhances durability and performance.
- Foam pre-cleaner traps large debris before it can clog the filter element and rob the engine of needed air.
- Industrial grade solenoid shift starter assures quick, reliable starts.
- Full-pressure oil lubrication system with spin-on filter works to keep oil cleaner, which reduces maintenance and extends engine life.

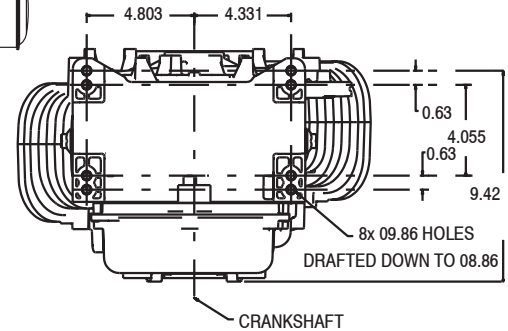
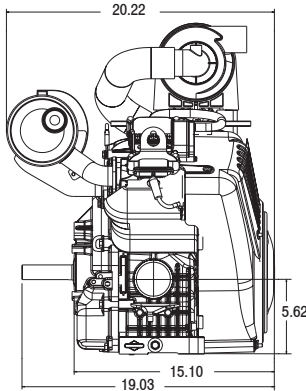
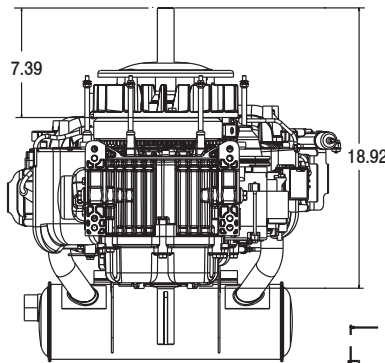
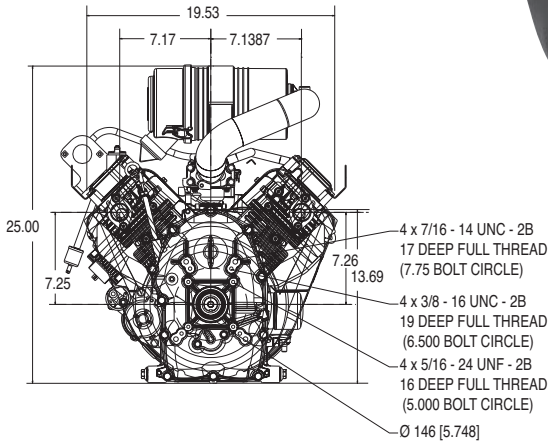

Model Type	Shipping Weight	Crankshaft	Crankshaft (P.T.O.) Extension	Dimension	Oil Filler & Drain	Governor	Controls	Exhaust System	Fuel Tank (Quarts)	Pulse Fuel Pump	Flange Mtg.	Oil Pump w/Filter	Remote Choke	Manual Choke	Top Governor Speed	Notes
543477																
0048	143	809982	1-1/8" dia., 1/4" Keyway & tapped 7/16-20	4(c)	*	M	MF	•	■	X	X	X		X	3600	◆
0065	155	809982	1-1/8" dia., 1/4" Keyway & tapped 7/16-20	4(c)	*	M	MF		■	X	X	X		X	3600	◆
0076	140	841513	1-1/8" dia., 1/4" Keyway & tapped 7/16-20	3(c)	*	M	R	•	■	X	X	X	X		3600	◆
0078		841683	Tapered, drill & tapped 5/16-24		*	M	AG	•	■	X	X	X	X		3750	◆
0079	132	841529	1-7/16" dia., 3/8" Keyway & tapped 5/8-18	4-1/2(c)	*	M	MF	•	■	X	X	X		X	3600	◆
0110	152	809982	1-1/8" dia., 1/4" Keyway & tapped 7/16-20	4(c)	*	M	R		■	X	X	X	X		3600	◆
0111	141	809982	1-1/8" dia., 1/4" Keyway & tapped 7/16-20	4(c)	*	M	R	•	■	X	X	X	X		3600	◆

• Exhaust manifold and muffler omitted. \* Oil fill and dipstick in cover; dual drain. ■ Fuel tank omitted.  
◆ Engine equipped with 12 Volt Gear Drive Starter and 20 Amp DC Alternator.