

# 16 HP VANGUARD™ Model Series 303700

Displacement 29.30 cu. in. (480 cc)

Bore 2.68 in. (68 mm)

Stroke 2.60 in. (66 mm)

Oil Capacity 48 fl. oz.  
(1.42 l) w/o Filter  
56 fl. oz.  
(1.66 l) w/Filter



COMMERCIAL POWER



## Features:

- Dura-Bore™ cast iron cylinder sleeve for extended life
- Dependable float feed type carburetor with integral fuel pump for remote mount fuel tank
- Maintenance-free Magnetron® electronic ignition for quick, dependable starts
- Dual-Clean™ air cleaner pleated paper filter with a foam pre-cleaner ensures maximum protection for extended engine life
- Full pressure lubrication with spin-on oil filter assures controlled lubrication for extended component life
- Overhead valve design (OHV) for cooler operation and longer valve life
- Buyer protection package provides two-year commercial engine warranty

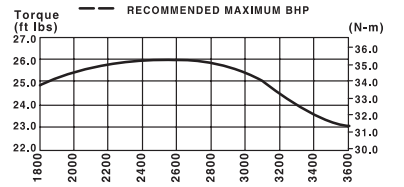
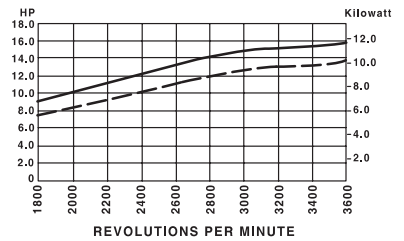
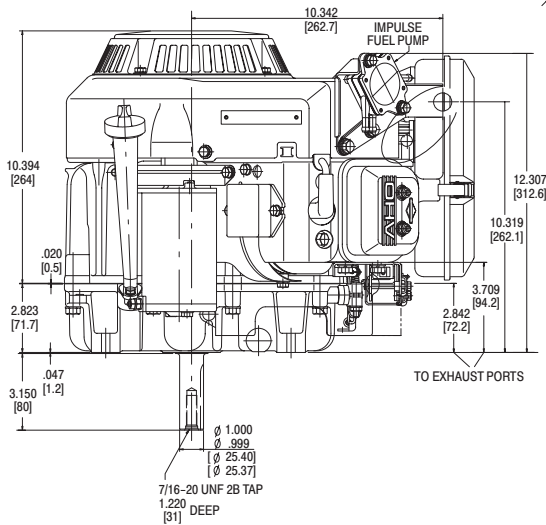
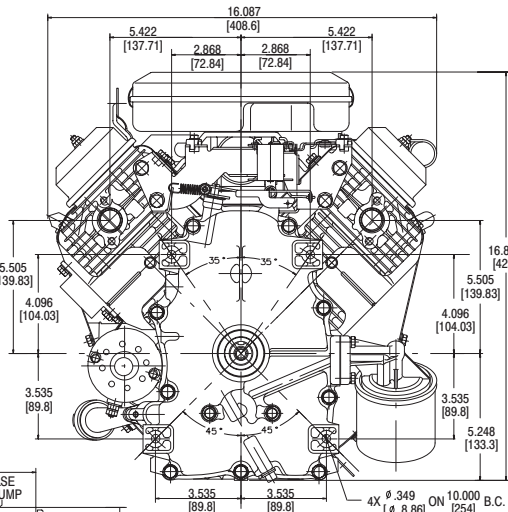
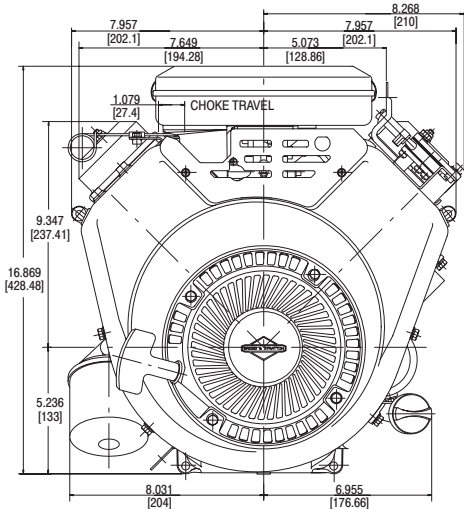

See Engine Accessories & Products Catalog Form MS-3880 for Exhaust Manifold and Muffler Options.

Model Type	Shipping Weight	Crankshaft	Crankshaft (P.T.O.) Extension	Dimension	Starter Position Bolt-On/Changeable	Governor	Controls	Exhaust System	Fuel Tank (Quarts)	Ground Wire Terminal	Ext. Oil Fill & Dipstick	Oil Pump w/Filter	Remote Choke	Top Governor Speed	Notes
303772															
1020	81	692159	Tapped 7/16-20, Keyway, 1" dia.	3-5/32(b)	9	M	R	• ■	X	X	X	X	X	3600	
303777															
1032	85	692159	Tapped 7/16-20, Keyway, 1" dia.	3-5/32(b)		M	R	• ■	X	X	X	X	X	3300	†

• Exhaust manifold and muffler omitted.

■ Fuel tank omitted.

† Engine equipped with 12 Volt Gear Drive Starter and 16 Amp DC Alternator.