

INTEK™ 21.0 Gross HP

540 CC

Bore 3.70 in. (94.0 mm)

Stroke 3.06 in. (77.8 mm)

Oil Capacity 48 fl. oz. (1.4 L)



Features:

- Dura-Bore™ cast iron cylinder sleeve for extended life
- Float carburetor for consistent easy starting
- Maintenance-free Magneton® electronic ignition for quick, dependable starts
- Maxi-Clean™ automotive type pleated paper air filter provides superior protection for long engine life
- Overhead valve design (OHV) for cooler operation and longer valve life
- Patented linear balancing system provides smoother performance
- Premium oil filter
- Platinum spark plugs for extended life
- Buyer protection package provides two-year consumer engine warranty

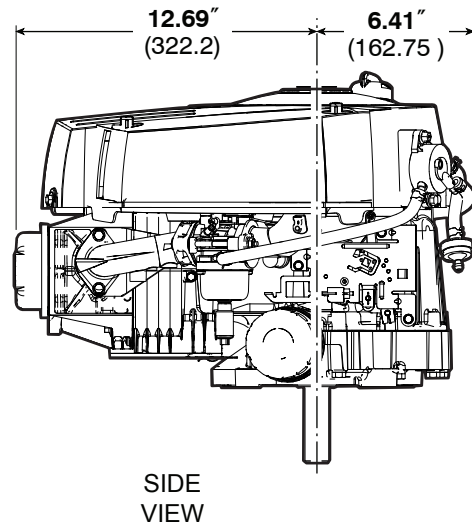
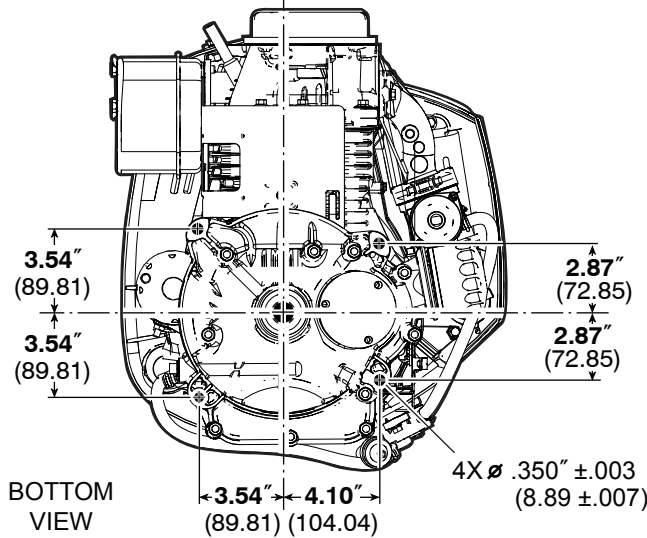
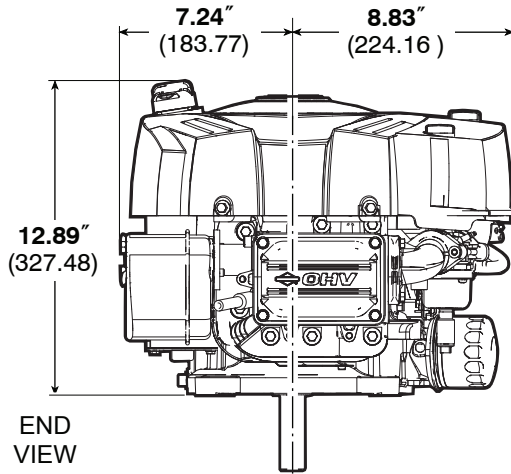

Model Type	Shipping Weight	Crankshaft	Crankshaft (P.T.O.) Extension	Dimension	Starter Position Bolt-On/Changeable	Ext. Oil Fill & Dipstick	Governor	Controls	Pulse Fuel Pump	Oil Pump with Filter	Choke-A-Matic®	Ground Wire Terminal	Fuel Tank (Quarts)	Top Governor Speed	Notes
331877 0036		697516	Tapped 7/16-20, Keyway, 1" dia.	3-5/32(b)		X	M	R	X	X	X	X	■	3300	▼

■ Fuel tank omitted. ▼ Engine equipped with 12 Volt Gear Drive Starter and 9 Amp DC Alternator.