

20 HP VANGUARD™ Model Series 351700

Displacement 34.75 cu. in. (570 cc)

Bore 2.83 in. (72 mm)

Stroke 2.75 in. (70 mm)

Oil Capacity

48 fl. oz. (1.42 l) w/o Filter

56 fl. oz. (1.66 l) w/Filter



COMMERCIAL POWER



Features:

- Dura-Bore™ cast iron cylinder sleeve for extended life
- Dependable float feed type carburetor with integral fuel pump for remote mount fuel tank
- Maintenance-free Magnetron® electronic ignition for quick, dependable starts
- Dual-Clean™ air cleaner pleated paper filter with a foam pre-cleaner ensures maximum protection for extended engine life
- Full pressure lubrication with spin-on oil filter assures controlled lubrication for extended component life
- Overhead valve design (OHV) for cooler operation and longer valve life
- Buyer protection package provides two-year commercial engine warranty

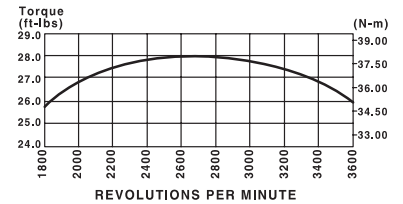
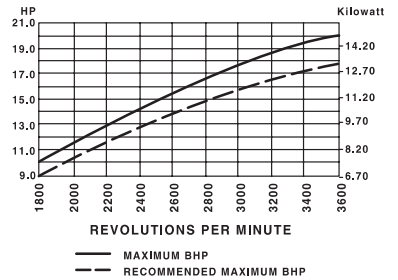
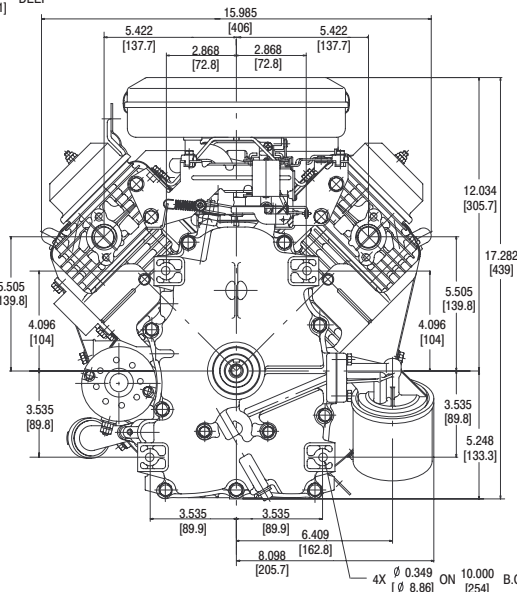
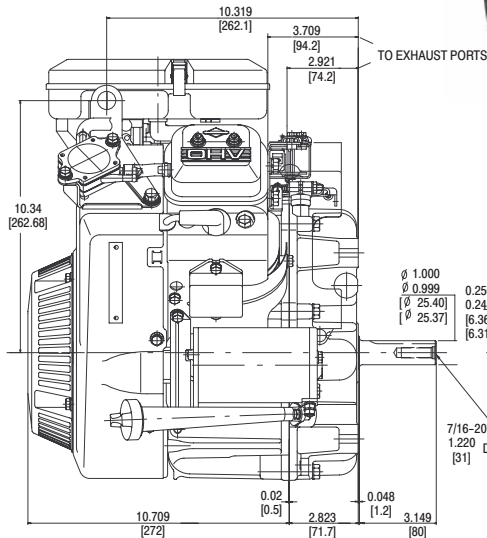

See Engine Accessories & Products Catalog Form MS-3880 for Exhaust Manifold and Muffler Options.

Model Type	Shipping Weight	Crankshaft	Crankshaft (P.T.O.) Extension	Dimension	Starter Position	Bolt-On/Changeable Governor	Controls	Exhaust System	Fuel Tank (Quarts)	Ground Wire Terminal	Ext. Oil Fill & Dipstick	Oil Pump w/Filter	Remote Choke	Top Governor Speed	Notes
351772															
1045	81	692172	Tapped 7/16-20, Keyway, 1" dia.	3-5/32(b)	9	M R	• ■	X X	X X	X X	X X	X X	X X	3600	
351777															
1036	89	692172	Tapped 7/16-20, Keyway, 1" dia.	3-5/32(b)		M R	• ■	X X	X X	X X	X X	X X	X X	3600	†

• Exhaust manifold and muffler omitted.

■ Fuel tank omitted.

† Engine equipped with 12 Volt Gear Drive Starter and 16 Amp DC Alternator.