

# ***OWNER'S MANUAL***

## ***KT17, KT19 Series II***

**Congratulations** – You have selected a fine four-cycle, twin cylinder, air-cooled engine. Kohler designs long life strength and on-the-job durability into each engine... making a Kohler engine dependable... dependability you can count on. Here are some reasons why:

- Parts subject to the most wear and tear (like cylinders, crankshaft, and camshaft) are made from precision formulated cast iron. Because the cast iron cylinders can be rebored, these engines can last even longer.
- Kohler engines are easy to service. All routine service areas (like the dipstick, oil filter, breaker points, air cleaner, spark plugs, and carburetor) are easily and quickly accessible.
- Every Kohler engine is backed by a worldwide network of over 10,000 distributors and dealers. Service support is just a phone call away. Call 1-800-544-2444 (U.S. & Canada) for Sales & Service assistance.

To keep your engine in top operating condition, follow the maintenance procedures in this manual.

## Safety Precautions

To ensure safe operations please read the following statements and understand their meaning. Also refer to your equipment owner's manual for other important safety information. This manual contains safety precautions which are explained below. Please read carefully.

### **WARNING**

Warning is used to indicate the presence of a hazard that *can* cause severe personal injury, death, or substantial property damage if the warning is ignored.

### **CAUTION**



Caution is used to indicate the presence of a hazard that *will* or can cause *minor* personal injury or property damage if the caution is ignored.

### **NOTE**

Note is used to notify people of installation, operation, or maintenance information that is important but not hazard-related.



### **For Your Safety!**

*These precautions should be followed at all times. Failure to follow these precautions could result in injury to yourself and others.*

 <b>WARNING</b>

<b>Explosive Fuel can cause fires and severe burns.</b>
Stop engine before filling fuel tank.

### **Explosive Fuel!**

*Gasoline is extremely flammable and its vapors can explode if ignited. Store gasoline only in approved containers, in well ventilated, unoccupied buildings, away from sparks or flames. Do not fill the fuel tank while the engine is hot or running, since spilled fuel could ignite if it comes in contact with hot parts or sparks from ignition. Do not start the engine near spilled fuel. Never use gasoline as a cleaning agent.*

 <b>WARNING</b>

<b>Rotating Parts can cause severe injury.</b>
Stay away while engine is in operation.

### **Rotating Parts!**



*Keep hands, feet, hair, and clothing away from all moving parts to prevent injury. Never operate the engine with covers, shrouds, or guards removed.*

 <b>WARNING</b>

<b>Hot Parts can cause severe burns.</b>
Do not touch engine while operating or just after stopping.

### **Hot Parts!**

*Engine components can get extremely hot from operation. To prevent severe burns, do not touch these areas while the engine is running—or immediately after it is turned off. Never operate the engine with heat shields or guards removed.*

 <b>CAUTION</b>

<b>Electrical Shock can cause injury.</b>
Do not touch wires while engine is running.

### **Electrical Shock!**

*Never touch electrical wires or components while the engine is running. They can be sources of electrical shock.*

<b>California Proposition 65 Warning</b>
<i>Engine exhaust from this product contains chemicals known to the State of California to cause cancer, birth defects, or other reproductive harm.</i>



## Safety Precautions (Cont.)

 <b>WARNING</b>

<b>Accidental Starts can cause severe injury or death.</b>  Disconnect and ground spark plug lead before servicing.



### **Accidental Starts!**

**Disabling engine. Accidental starting can cause severe injury or death.** Before working on the engine or equipment, disable the engine as follows: 1) Disconnect the spark plug lead(s). 2) Disconnect negative (-) battery cable from battery.

 <b>WARNING</b>

<b>Carbon Monoxide can cause severe nausea, fainting or death.</b>  Do not operate engine in closed or confined area.

### **Lethal Exhaust Gases!**

*Engine exhaust gases contain poisonous carbon monoxide. Carbon monoxide is odorless, colorless, and can cause death if inhaled. Avoid inhaling exhaust fumes, and never run the engine in a closed building or confined area.*

 <b>WARNING</b>

<b>Explosive Gas can cause fires and severe acid burns.</b>  Charge battery only in a well ventilated area. Keep sources of ignition away.

### **Explosive Gas!**

*Batteries produce explosive hydrogen gas while being charged. To prevent a fire or explosion, charge batteries only in well ventilated areas. Keep sparks, open flames, and other sources of ignition away from the battery at all times. Keep batteries out of the reach of children. Remove all jewelry when servicing batteries.*

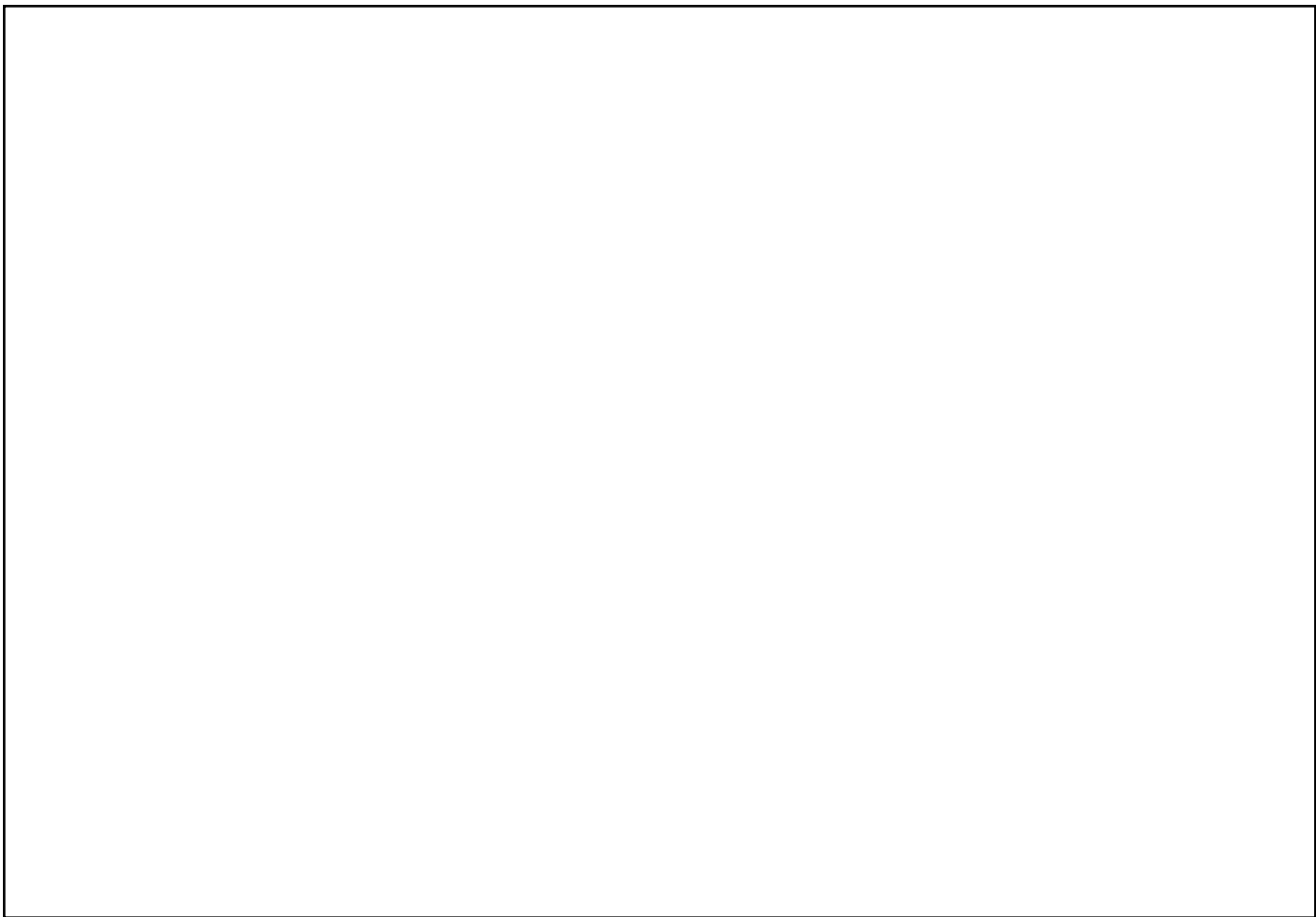
*Before disconnecting the negative (-) ground cable, make sure all switches are OFF. If ON, a spark will occur at the ground cable terminal which could cause an explosion if hydrogen gas or gasoline vapors are present.*



**Figure 1. Typical KT Engine.**

**Oil Recommendations**

Using the proper type and weight of oil in the crankcase is extremely important. So is checking oil daily and changing oil and filter regularly. Failure to use the correct oil, or using dirty oil, causes premature engine wear and failure.

Before each start, make sure the crankcase is filled with proper type and quantity of oil.

**Oil Type**

Use high quality detergent oil of **API (American Petroleum Institute) service class SG, SH, SJ or higher**. Select the viscosity based on the air temperature at the time of operation as shown in the following table.

RECOMMENDED SAE VISCOSITY GRADES	
	<p>TEMPERATURE RANGE EXPECTED TO OCCUR AT NEXT OIL CHANGE</p>

**Figure 2. Viscosity Grades Table.**

**Straight 30-weight (Kohler "Magnum") oil is preferred.** SAE 10W-30 oil is **not** recommended above 32°F. Using this oil substantially increases oil consumption and combustion chamber deposits.

NOTE: Using other than service class SG, SH, SJ or higher oil or extending oil change intervals longer than recommended can cause engine damage.

A logo or symbol on oil containers identifies the API service class and SAE viscosity grade. See Figure 3.



**Figure 3. Oil Container Logo.**

Refer to "Maintenance Instructions" beginning on page 7 for detailed oil check, oil change, and oil filter change procedures.

---

## Fuel Recommendations



### **WARNING: Explosive Fuel!**

*Gasoline is extremely flammable and its vapors can explode if ignited. Store gasoline only in approved containers, in well ventilated, unoccupied buildings, away from sparks or flames. Do not fill the fuel tank while the engine is hot or running, since spilled fuel could ignite if it comes in contact with hot parts or sparks from ignition. Do not start the engine near spilled fuel. Never use gasoline as a cleaning agent.*

## General Recommendations

Purchase gasoline in small quantities and store in clean, approved containers. A container with a capacity of 2 gallons or less with a pouring spout is recommended. Such a container is easier to handle and helps eliminate spillage during refueling.

Do not use gasoline left over from the previous season, to minimize gum deposits in your fuel system and to ensure easy starting.

Do not add oil to the gasoline.

Do not overfill the fuel tank. Leave room for the fuel to expand.

## Fuel Type

For best results use only clean, fresh, **unleaded** gasoline with a pump sticker octane rating of 87 or higher. In countries using the Research method, it should be 90 octane minimum.

Unleaded gasoline is recommended as it leaves less combustion chamber deposits. Leaded gasoline may be used in areas where unleaded is not available and exhaust emissions are not regulated. Be aware however, that the cylinder head will require more frequent service.

## Gasoline/Alcohol blends

Gasohol (up to 10% ethyl alcohol, 90% unleaded gasoline by volume) is approved as a fuel for Kohler engines. Other gasoline/alcohol blends are not approved.

## Gasoline/Ether blends

Methyl Tertiary Butyl Ether (MTBE) and unleaded gasoline blends (up to a maximum of 15% MTBE by volume) are approved as a fuel for Kohler engines. Other gasoline/ether blends are not approved.

## Engine Identification Numbers

When ordering parts, or in any communication involving an engine, always give the **Model, Specification, and Serial Numbers** of the engine.

The engine identification numbers appear on decal (or decals) affixed to the engine shrouding. Include letter suffixes, if there are any.

Record your engine identification numbers on the identification label below (Figure 4) for future reference.

**MODEL NO.**  
**SPEC. NO.**  
**DISPL (CC)**  
**SERIAL NO.**  
REFER TO OWNER'S MANUAL FOR  
SAFETY, MAINTENANCE SPECS  
AND ADJUSTMENTS. FOR SALES  
AND SERVICE IN US/CANADA CALL:  
1-800-544-2444  
**KOHLER engines**  
KOHLER CO. KOHLER, WI USA

**Figure 4. Engine Identification Label.**

---

# Operating Instructions

Also read the operating instructions of the equipment this engine powers.

## Pre-Start Checklist

- Check oil level. Add oil if low. Do not overfill.
- Check fuel level. Add fuel if low.
- Check cooling air intake areas and external surfaces of engine. Make sure they are clean and unobstructed.
- Check that the air cleaner components and all shrouds, equipment covers, and guards are in place and securely fastened.
- Check that any clutches or transmissions are disengaged or placed in neutral. This is especially important on equipment with hydrostatic drive. The shift lever must be exactly in neutral to prevent resistance which could keep the engine from starting.



### **WARNING: Lethal Exhaust Gases!**

Engine exhaust gases contain poisonous carbon monoxide. Carbon monoxide is odorless, colorless, and can cause death if inhaled. Avoid inhaling exhaust fumes, and never run the engine in a closed building or confined area.

## Cold Weather Starting Hints

1. Be sure to use the proper oil for the temperature expected. See Figure 2 on page 4.
2. Declutch all possible external loads.
3. Set speed control at part throttle position.
4. Be sure the battery is in good condition. A warm battery has much more starting capacity than a cold battery.
5. Use fresh winter grade fuel. NOTE: Winter grade gasoline has a higher volatility to improve starting. Do not use gasoline left over from summer.

## Starting

1. **On a Cold Engine** – Place the throttle control **midway** between the **"slow"** and **"fast"** positions. Place the choke control into the **"on"** position.

**On a Warm Engine (Normal Operating Temperatures)** – Place the throttle control **midway** between the **"slow"** and **"fast"** positions. Place the choke control into the **"off"** position.

2. Activate the starter switch. Release the switch as soon as the engine starts.

NOTE: After starting the engine, it may be necessary to leave the choke partially **"on"** for a few minutes before moving it to the **"off"** position.

NOTE: Do not crank the engine continuously for more than 10 seconds at a time. If the engine does not start, allow a 60 second cool down period between starting attempts. Failure to follow these guidelines can burn out the starter motor.

NOTE: If the engine develops sufficient speed to disengage the starter but does not keep running (a false start), the engine rotation must be allowed to come to a complete stop before attempting to restart the engine. If the starter is engaged while the flywheel is rotating, the starter pinion and flywheel ring gear may clash, resulting in damage to the starter.

If the starter does not turn the engine over, shut off starter immediately. Do not make further attempts to start the engine until the condition is corrected. Do not jump start using another battery (refer to "Battery" below). See your Kohler Engine Service Dealer for trouble analysis.

3. **On a Cold Engine** – Gradually return the choke control to the **"off"** position after the engine starts and warms up.

## Stopping

1. If possible, remove the load by disengaging all PTO attachments.
2. Place the throttle control **midway\*** between the **"stop"** and **"fast"** positions. Allow the engine to run for a minimum of 15 seconds; then stop the engine.

\*NOTE: Minimum engine speed of 2400 RPM.

## Battery

A 12 volt battery is normally used. Refer to the operating instructions of the equipment this engine powers for specific battery requirements.

If the battery charge is not sufficient to crank the engine, recharge the battery (see page 11).

## Operating

Optional spark arrestor mufflers are available from your Kohler Engine Service Dealer. Check your local laws and statutes regarding engine spark arrestor muffler requirements.

### Angle of Operation

This engine will operate continuously at angles up to 30° in any direction. Check oil level to assure crankcase oil level is at the “F” mark.

Refer to the operating instructions of the equipment this engine powers. Because of equipment design or application, there may be more stringent restrictions regarding the angle of operation.

NOTE: Do not operate this engine continuously at angles exceeding 30° in any direction. Engine damage could result from insufficient lubrication.

## Cooling

NOTE: If debris builds up on the grass screen or other cooling air intake areas, stop the engine immediately and clean. Operating the engine with blocked or dirty air intake and cooling areas can cause extensive damage due to overheating.



### WARNING: Hot Parts!

Engine components can get extremely hot from operation. To prevent severe burns, do not touch these areas while the engine is running—or immediately after it is turned off. Never operate the engine with heat shields or guards removed.

### Engine Speed

NOTE: Do not tamper with the governor setting to increase the maximum engine speed. Overspeed is hazardous and will void the engine warranty.

## Maintenance Instructions



### WARNING: Accidental Starts!

**Disabling engine. Accidental starting can cause severe injury or death.** Before working on the engine or equipment, disable the engine as follows: 1) Disconnect the spark plug lead(s). 2) Disconnect negative (-) battery cable from battery.

## Maintenance Schedule

These required maintenance procedures should be performed at the frequency stated in the table. They should also be included as part of any seasonal tune-up.

Frequency	Maintenance Required
As Specified on pages 8 & 9	<ul style="list-style-type: none"><li>• Change oil.</li><li>• Change oil filter.</li></ul>
Daily or Before Starting Engine	<ul style="list-style-type: none"><li>• Fill fuel tank.</li><li>• Check oil level.</li><li>• Check air cleaner for dirty<sup>1</sup>, loose, or damaged parts.</li><li>• Check air intake and cooling areas, clean as necessary<sup>1</sup>.</li></ul>
Every 25 Hours	<ul style="list-style-type: none"><li>• Service precleaner element<sup>1</sup>.</li></ul>
Every 50 Hours	<ul style="list-style-type: none"><li>• Remove cooling shrouds and clean cooling areas<sup>1</sup>.</li></ul>
Every 100 Hours	<ul style="list-style-type: none"><li>• Service air cleaner element<sup>1</sup>.</li><li>• Check spark plug condition and gap.</li></ul>
Annually or Every 500 Hours	<ul style="list-style-type: none"><li>• Have bendix starter drive serviced<sup>2</sup>.</li><li>• Have breaker points checked<sup>2</sup>.</li><li>• Have ignition timing checked<sup>2</sup>.</li><li>• Have valve and tappet clearance checked<sup>2</sup>.</li><li>• Have cylinder heads serviced<sup>2,3</sup>.</li></ul>

<sup>1</sup>Perform these maintenance procedures more frequently under extremely dusty, dirty conditions.

<sup>2</sup>Have a Kohler Engine Service Dealer perform this service.

<sup>3</sup>250 hours when leaded gasoline is used.

## Check Oil Level

The importance of checking and maintaining the proper oil level in the crankcase cannot be overemphasized. Check oil **BEFORE EACH USE** as follows:

1. Make sure the engine is stopped, level, and is cool so the oil has had time to drain into the sump.
2. To keep dirt, grass clippings, etc., out of the engine, clean the area around the oil fill cap or dipstick before removing it.
3. Remove the dipstick; wipe oil off. Reinsert the dipstick and push it all the way down into the tube.
4. Remove the dipstick and check the oil level.

The oil level should be up to, but not over, the "F" mark on the dipstick. See Figure 5.

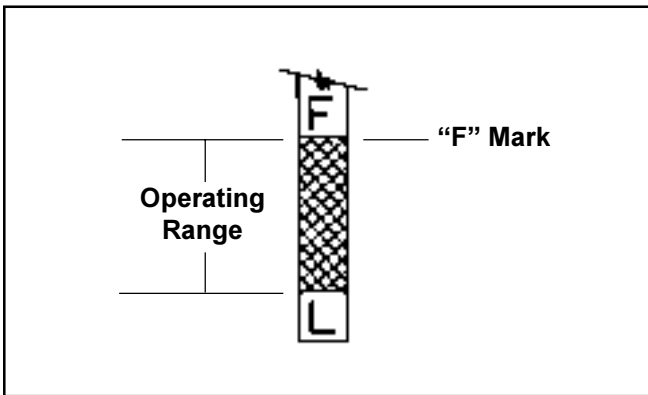

Figure 5. Oil Level Dipstick.

5. If the level is low, add oil of the proper type, up to the "F" mark on the dipstick. (Refer to "Oil Type" on page 4.) Always check the level with the dipstick before adding more oil.

NOTE: To prevent extensive engine wear or damage, always maintain the proper oil level in the crankcase. Never operate the engine with the oil level below the "L" mark or over the "F" mark on the dipstick.

## Oil Sentry™

Some engines are equipped with an optional Oil Sentry™ oil pressure switch. If the oil pressure decreases below an acceptable level, the Oil Sentry™ will either shut off the engine or activate a warning signal, depending on the application.

NOTE: Make sure the oil level is checked **BEFORE EACH USE** and is maintained up to the "F" mark on the dipstick. This includes engines equipped with Oil Sentry™.

## Change Oil and Oil Filter

### Change Oil

For a new engine, change oil after the first **5 hours** of operation. Thereafter, change oil as shown in the "Oil Change Intervals" table.

### Oil Change Intervals

Oil Type	Engine Type	Interval
<b>Temperature ABOVE 32° F (0° C)</b>		
SAE 30	With Filter	50 Hours*
	Without Filter	25 Hours
Multiviscosity	With Filter	25 Hours
	Without Filter	25 Hours
<b>Temperature BELOW 32° F (0° C)</b>		
Multiviscosity	With Filter	50 Hours
	Without Filter	25 Hours

\*NOTE: 25 hours for continuous and/or heavy duty operation.

Change the oil while the engine is still warm. The oil will flow freely and carry away more impurities. Make sure the engine is level when filling, checking, or changing the oil.

Change the oil as follows:

1. Remove the oil drain plug and oil fill cap. Tilt the engine slightly towards the oil drain to obtain better drainage.
2. Reinstall the drain plug. Make sure it is tightened securely.
3. Fill with new oil of the proper type to the "F" mark on the dipstick. Always check the level on the dipstick before adding more oil.

NOTE: To prevent extensive engine wear or damage, always maintain the proper oil level in the crankcase. Never operate the engine with the oil level below the "L" mark or over the "F" mark on the dipstick.

4. Reinstall the oil fill cap. Make sure it is tightened securely.



---

## Change Oil Filter

Some engines are equipped with an oil filter. Replace the oil filter *every other* oil change, in accordance with the "Oil Change Intervals" table on page 8. Always use a genuine Kohler oil filter, Part No. 52 050 02-S, and replace as follows:

1. Drain the oil from the engine crankcase.
2. Allow the oil filter to drain.
3. Before removing the oil filter, clean the area around the oil filter to keep dirt and debris out of the engine. Remove the old filter. Wipe off the surface where the filter mounts.
4. Place a new replacement filter in a shallow pan with the open end up. Pour new oil of the proper type, in through the threaded center hole. Stop pouring when the oil reaches the bottom of the threads. Allow a minute or two for the oil to be absorbed by the filter material.
5. Put a drop of oil on your fingertip and wipe it on the rubber gasket.
6. Install the new oil filter to the filter adapter. Turn the oil filter clockwise until the rubber gasket contacts the filter adapter, then tighten the filter and additional **2/3 to 1 turn**.
7. Reinstall drain plug. Make sure it is tight.
8. Fill the crankcase with new oil of the proper type to the "F" mark on the dipstick. Add an additional 1/2 pint of oil for the filter capacity. See "Specifications" on page 15.
9. Test run the engine to check for leaks. Stop the engine, allow a minute for the oil to drain down, and recheck the level on the dipstick. Make sure oil level is up to but not over the "F" mark on the dipstick.

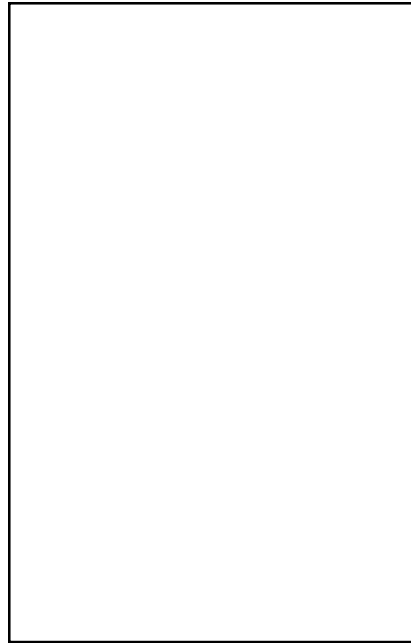

**Figure 6. Oil Filter and Optional Oil Sentry™ Switch.**

## Service Precleaner and Air Cleaner Element

This engine is equipped with a replaceable, high density paper air cleaner element. Some engines are also equipped with an oiled, foam precleaner which surrounds the paper element. See Figure 7.

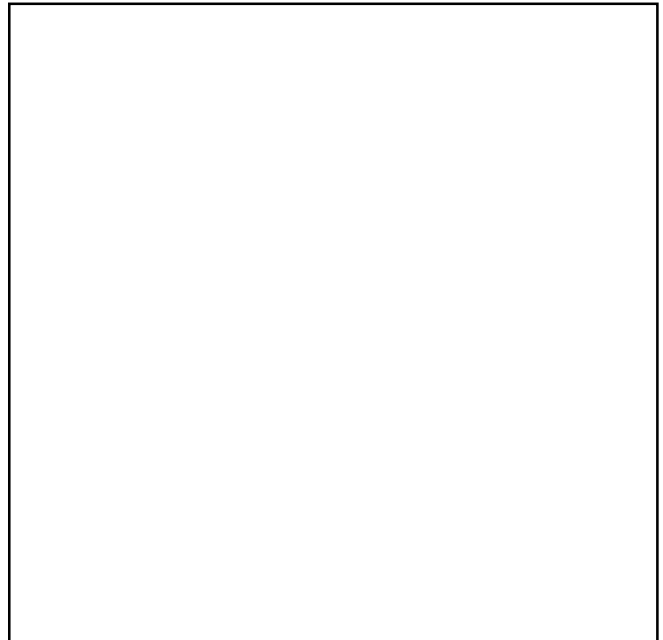

**Figure 7. Air Cleaner Housing Components.**

Check the air cleaner **daily or before starting the engine**. Check for buildup of dirt and debris around the air cleaner system. Keep this area clean. Also check for loose or damaged components. Replace all bent or damaged air cleaner components.

---

**NOTE:** Operating the engine with loose or damaged air cleaner components could allow unfiltered air into the engine causing premature wear and failure.

### Service Precleaner

If so equipped, wash and reoil the precleaner every **25 hours** of operation (more often under extremely dusty or dirty conditions).

1. Remove wing nuts, air cleaner cover, element cover, seals, and element cover.
2. Remove precleaner from paper element. Wash the precleaner in warm water with detergent.
3. Rinse the precleaner thoroughly until all traces of detergent are eliminated. Squeeze out excess water (do not wring). Air dry.
4. Saturate precleaner in clean, fresh engine oil and squeeze out excess oil.
5. Reinstall precleaner over paper element.
6. When precleaner replacement is necessary always use genuine Kohler parts.

### Service Paper Element

Every **100 hours** of operation (more often under extremely dusty or dirty conditions), check the paper element. Replace the element as necessary.

1. Remove the precleaner (if so equipped) from the paper element.
2. **Do not** wash the paper element or use pressurized air, as this will damage the element. Replace a dirty, bent, or damaged element with a genuine Kohler element. Handle new elements carefully; do not use if the sealing surfaces are bent or damaged.
3. With air cleaner disassembled, check the base plate. Make sure it is secured and not bent or damaged. Also check the element cover, seals, and breather tube for damage or improper fit. Replace all damaged components.

**NOTE:** Operating the engine with damaged or loose components could allow unfiltered air into the engine causing premature wear and failure.

4. Reinstall the paper element.
5. If so equipped, install the precleaner (washed and oiled) over paper element.

6. Reinstall element cover, seals, air cleaner cover and wing nuts. Tighten wing nuts 1/2 to 1 full turn after nuts contacts cover. Do not overtighten.
7. When air cleaner element replacement is necessary always use genuine Kohler parts.

### Clean Air Intake/Cooling Areas

To ensure proper cooling, make sure the grass screen, cooling fins, and other external surfaces of the engine are kept clean **at all times**.

Every **50 hours** of operation (more often under extremely dusty, dirty conditions), remove the blower housing and other cooling shrouds. Clean the cooling fins and external surfaces as necessary. Make sure the cooling shrouds are reinstalled.

**NOTE:** Operating the engine with a blocked grass screen, dirty or plugged cooling fins, and/or cooling shrouds removed, will cause engine damage due to overheating.

### Check Spark Plug

Every **100 hours** of operation, remove the spark plugs, check condition, and reset gaps or replace with new plugs as necessary. Use a Champion® type RV15YC (or equivalent) spark plug.

1. Before removing spark plugs, clean the area around base of plugs to keep dirt and debris out of the engine.
2. Remove plugs and check condition. Replace plugs if worn or reuse is questionable.

**NOTE:** Do not clean the spark plug in a machine using abrasive grit. Some grit could remain in the spark plug and enter the engine causing extensive wear and damage.

3. Check gaps using a wire feeler gauge. Adjust the gaps to **0.025 in. (0.65 mm)** by carefully bending the ground electrode. See Figure 8.
4. Reinstall spark plugs into the cylinder heads. Torque spark plugs to **10-15 ft. lb. (14-20 N·m)**.

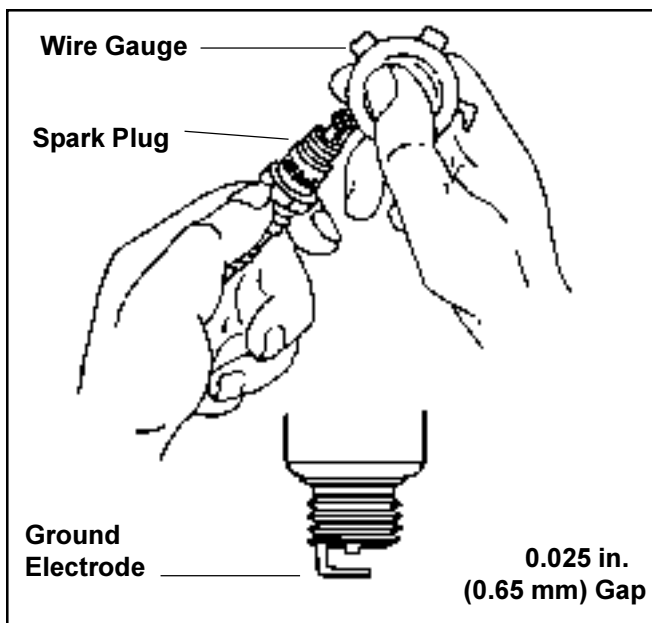

Figure 8. Servicing Spark Plug.

## Battery Charging



### **WARNING: Explosive Gas!**

Batteries produce explosive hydrogen gas while being charged. To prevent a fire or explosion, charge batteries only in well ventilated areas. Keep sparks, open flames, and other sources of ignition away from the battery at all times. Keep batteries out of the reach of children. Remove all jewelry when servicing batteries.

Before disconnecting the negative (–) ground cable, make sure all switches are OFF. If ON, a spark will occur at the ground cable terminal which could cause an explosion if hydrogen gas or gasoline vapors are present.

## Fuel Filter

Some engines are equipped with an in-line fuel filter. Periodically inspect the filter and replace when dirty. Use a genuine Kohler filter.

## Carburetor Troubleshooting and Adjustments

KT17 and KT19 engines are equipped with one of two basic types of carburetors – Kohler or Walbro – fixed main jet or adjustable main jet.

The carburetor is designed to deliver the correct fuel-to-air mixture to the engine under all operating conditions. The main fuel and idle fuel needles on adjustable jet carburetors are set at the factory and normally do not require further adjustment. On fixed jet carburetors, the low idle fuel needle is also set at the factory and normally does not need further adjustment. The main fuel jet is calibrated and installed at the factory and is not adjustable\*.

\*NOTE: KT17 and KT19 engines with fixed jet carburetors, operating at altitudes above approximately 6000 ft., may require a special "high altitude" main jet. See your Kohler Engine Service Dealer for further information.

## Troubleshooting

If engine troubles are experienced that appear to be fuel system related, check the following areas before adjusting the carburetor.

- Make sure the fuel tank is filled with clean, fresh gasoline.
- Make sure the fuel tank cap vent is not blocked and that it is operating properly.
- If the fuel tank is equipped with a shutoff valve, make sure it is open.
- If the engine is equipped with an in-line fuel filter, make sure it is clean and unobstructed. Replace the filter if necessary.
- Make sure fuel is reaching the carburetor. This includes checking the fuel lines and fuel pump for restrictions or faulty components, replace as necessary.
- Make sure the air cleaner element is clean and all air cleaner element components are fastened securely.

If, after checking the items listed above, the engine is hard to start, runs roughly, or stalls at low idle speed, it may be necessary to adjust or service the carburetor.

NOTE: Carburetor adjustments should be made only after the engine has warmed up.

## Kohler Carburetor Adjustment

1. With the engine stopped, turn the low idle fuel and main fuel adjusting needles **in** (clockwise) until they bottom **lightly**.

NOTE: The tip of the idle fuel and main fuel adjusting needles are tapered to critical dimensions. Damage to the needles and the seats in carburetor body will result if the needles are forced.

2. **Preliminary Settings:** Turn the adjusting needles **out** (counterclockwise) from lightly bottomed to the positions shown in the chart on page 12.

### Kohler Adjustable Jet

	Low Idle	Main Fuel
KT17	1 turn	2-1/2 turns
KT19	1 turn	2-1/2 turns

- Start the engine and run at half throttle for 5 to 10 minutes to warm up. The engine must be warm before making final settings (steps 4, 5, 6, and 7).
- Main Fuel Needle Setting:** This adjustment is required for adjustable main jet carburetors only. If the carburetor is a fixed main jet type, refer to Walbro adjustment.

Turn the main fuel adjusting needle **out** (counterclockwise) from the preliminary setting until the engine speed decreases (rich). Note the position of the needle.

Now turn the adjusting needle **in** (clockwise). The engine speed may increase, then it will decrease as the needle is turned in (lean). Note the position of the needle.

Set the adjusting needle **midway** between the rich and lean settings.

- Low Idle Speed Setting:** Place the throttle control into the “idle” or “slow” position. Set the low idle speed to **1200 RPM\*** ( $\pm 75$  RPM) by turning the low idle speed adjusting screw **in or out**. Check the speed using a tachometer.

\*NOTE: The actual low idle speed depends on the application – refer to equipment manufacturer's recommendations. The recommended low idle speed for basic engines is 1200 RPM. To ensure best results when setting the low idle fuel needle, the low idle speed must not exceed 1500 RPM.

- Low Idle Fuel Needle Setting:** Place the throttle into the “idle” or “slow” position.

Turn the low idle fuel adjusting needle **out** (counterclockwise) from the preliminary setting until the engine speed decreases (rich). Note the position of the needle.

Now turn the adjusting needle **in** (clockwise). The engine speed may increase, then it will decrease as the needle is turned in (lean). Note the position of the needle.

Set the adjusting needle **midway** between the rich and lean settings.

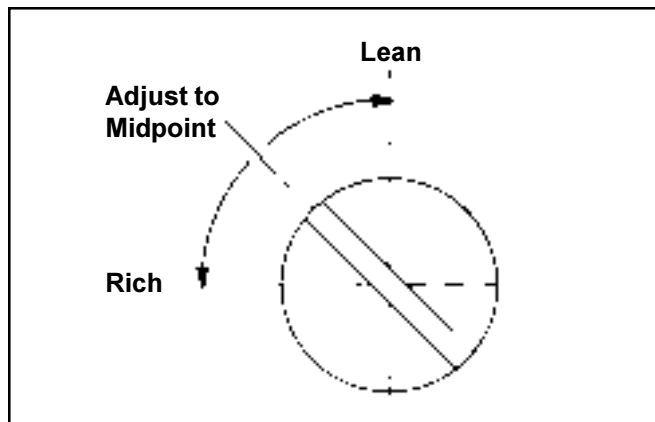

Figure 9.

- Recheck the idle speed using a tachometer. Readjust the speed as necessary.

### Walbro Carburetor Adjustment

In general, turning the adjusting needles **in** (clockwise) decreases the supply of fuel to the carburetor. This gives a *leaner* fuel-to-air mixture. Turning the adjustment needles **out** (counterclockwise) increases the supply of fuel to the carburetor.

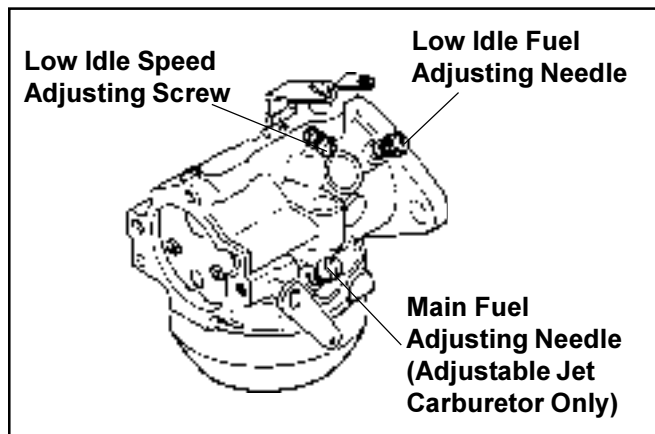

Figure 10.

NOTE: The tip of the low idle fuel and main fuel adjusting needles are tapered to critical dimensions. Damage to the needles and the seats in carburetor body will result if the needles are forced.

- With the engine stopped, turn the adjusting needle(s) **in** (clockwise) until it bottoms *lightly*.
- Preliminary Settings:** Turn the adjusting needle(s) **out** (counterclockwise) from lightly bottomed as follows or to the rich side of adjustment.

**Walbro Fixed Jet**

	<b>Low Idle</b>
KT17	1-1/4 turns
KT19	1-1/4 turns

**Walbro Adjustable Jet**

	<b>Low Idle</b>	<b>Main Fuel</b>
KT17	1-1/4 turns	1-1/4 turns
KT19	1-1/4 turns	1 turn

- Start the engine and run at half throttle for five to ten minutes to warm up. The engine must be warm before making final settings.
- Main Fuel Needle Setting:** *This adjustment is required only for adjustable main jet carburetors. If the carburetor is a fixed main jet type, disregard this setting.*

Place the throttle into the "fast" position.

Turn the adjusting needle **in** (clockwise). The engine speed may increase, then it will decrease as the needle is turned **in** (lean). Note the position of the needle. Back the needle out approximately 1/4 turn. See Figure 11 below for best main fuel performance.

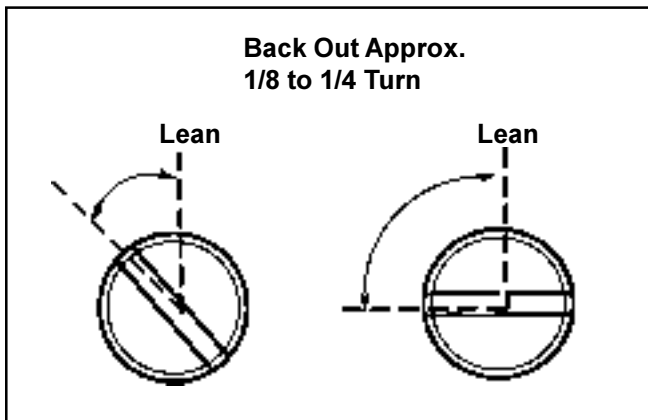

**Figure 11. Optimum Main Fuel Setting.**

- Low Idle Speed Setting:** Place the throttle control into the "idle" or "slow" position. Set the low idle speed to 1200 RPM\* ( $\pm 75$  RPM) by turning the low idle speed adjusting screw in or out. Check the speed using a tachometer.

\*NOTE: The actual low idle speed depends on the application. Refer to the equipment manufacturer's instructions for specific low idle speed settings. To ensure best results when setting the low idle fuel needle, the low idle speed must not exceed 1500 RPM.

- Low Idle Fuel Needle Setting:** Place the throttle into the "idle" or "slow" position.

Turn the adjusting needle **in** (clockwise). The engine speed may increase, then it will decrease as the needle is turned in (lean). Note the position of the needle.

Back the needle out approximately 1/8 to 1/4 turn. See Figure 12 below for best low idle fuel performance.

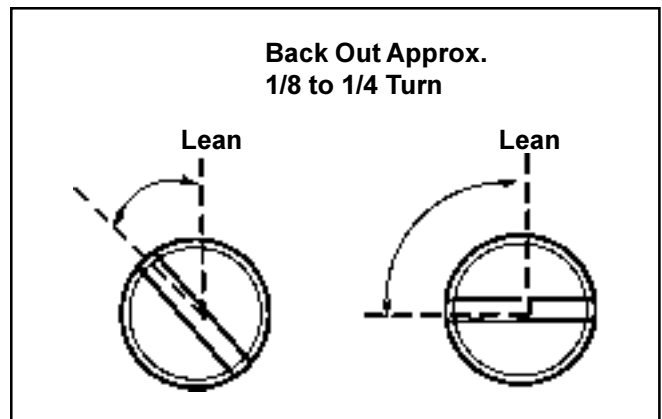

**Figure 12. Optimum Low Idle Fuel Setting.**

## Troubleshooting

When troubles occur, be sure to check the simple causes which, at first, may seem to obvious to be considered. For example, a starting problem could be caused by an empty fuel tank. Some common causes of engine troubles are listed in the following table.

Do not attempt to service or replace major engine components, or any items that require special timing or adjustment procedures. Have your Kohler Engine Service Dealer do this work.

Possible Cause Problem	No Fuel	Improper Fuel	Dirt In Fuel Line	Dirty Grass Screen	Incorrect Oil Level	Engine Overloaded	Dirty Air Cleaner	Faulty Spark Plug
Will Not Start	•		•			•	•	•
Hard Starting	•	•	•			•	•	•
Stops Suddenly	•		•	•	•	•	•	
Lacks Power		•	•	•	•	•	•	•
Operates Erratically		•	•	•		•	•	•
Knocks or Pings		•		•		•		•
Skips or Misfires		•	•	•			•	•
Backfires			•			•	•	•
Overheats			•	•	•	•	•	
High Fuel Consumption							•	•

## Storage

If the engine will be out of service for two months or more, use the following storage procedure:

1. Clean the exterior surfaces of the engine.
2. Change the oil and filter while the engine is still warm from operation. See "Change Oil and Oil Filter" on page 8.
3. The fuel system must be completely emptied, or the gasoline must be treated with a stabilizer to prevent deterioration. If you choose to use a stabilizer, follow the manufacturers recommendations, and add the correct amount for the capacity of the fuel system. Fill the fuel tank with clean, fresh gasoline. Run the engine for 2-3 minutes to get stabilized fuel into the carburetor.

To empty the system, run the engine until the fuel tank and system are empty.

4. Remove the spark plugs. Add one tablespoon of engine oil into each spark plug hole. Install plugs, but do not connect the plug leads. Crank the engine two or three revolutions.
5. Remove the spark plugs. Cover one spark plug hole with your thumb, and turn the engine over until the piston is at the top of its stroke. (Pressure against thumb is greatest.) Repeat on other side. Reinstall the plugs, but do not connect the plug leads.
6. Store the engine in a clean, dry place.

## Parts Ordering

The engine Specification, Model, and Serial Numbers are required when ordering replacement parts from your Kohler Engine Service Dealer. These numbers are found on the identification plate which is affixed to the engine shrouding. Include letter suffixes if there are any. See "Engine Identification Numbers" on page 5.

*Always insist on genuine Kohler parts.* All genuine Kohler parts meet strict standards for fit, reliability, and performance.

## Major Repair

Major repair information is available in Kohler Engine Service Manuals. However, major repair generally requires the attention of a trained mechanic and the use of special tools and equipment. Your Kohler Engine Service Dealer has the facilities, training, and genuine Kohler replacement parts necessary to perform this service. For Sales & Service assistance call 1-800-544-2444 (U.S. & Canada) or contact your Kohler Engine Dealer or Service Distributor, he's in the Yellow Pages under Engines-Gasoline.

## Model Designation

Model KT17S for example: KT indicates K-Series twin cylinder engine, 17 indicates horsepower. Letter suffixes following the model numbers designates a specific version, as follows:

Suffix	Designates
EP	Generator Set
Q	Quiet Model
S	Electric Start
G	Tapered Crankshaft (Generator Application)

## Specifications

Model:	KT17	KT19
Bore:	inches (millimeters) 3.12 (79.2)	3.12 (79.2)
Stroke:	inches (millimeters) 2.75 (69.85)	3.06 (78.0)
Displacement:	cubic inches (cubic centimeters) 42.18 (691.3)	46.98 (769.8)
Power (@3600 RPM):	horsepower (kilowatts) 17 (12.7)	19 (14.2)
Weight:	lbs. (kilograms) 128 (58.1)	128 (58.1)
Oil Capacity:	U.S. quarts (liters) 1.5 (1.4) <sup>1</sup>	1.5 (1.4) <sup>1</sup>
Spark Plug Gap:	inches (millimeters) 0.025 (0.65)	0.025 (0.65)
Spark Plug Type:	Champion or Equiv. RV15YC	RV15YC
Breaker Point Gap (Nominal)	inches (millimeters) 0.020 (0.508) <sup>2</sup>	0.020 (0.508) <sup>2</sup>

<sup>1</sup>An additional 1/2 pint (0.24 L) required when oil filter is changed. For best results, fill to "F" mark on dipstick as opposed to adding a given quantity of oil.

<sup>2</sup>After setting point gap, start engine and check timing using a timing light – adjust points as necessary.

### LIMITED 1 YEAR ENGINE WARRANTY

We warrant to the original consumer that each new engine sold by us will be free from manufacturing defects in materials or workmanship in normal service for a period of one (1) year from date of purchase, provided it is operated and maintained in accordance with Kohler Co.'s instructions and manuals.

Our obligation under this warranty is expressly limited, at our option, to the replacement or repair at Kohler Co., Kohler, Wisconsin 53044, or at a service facility designated by us, of such part or parts as inspection shall disclose to have been defective.

#### EXCLUSIONS:

This warranty does not apply to defects caused by casualty or unreasonable use, including faulty repairs by others and failure to provide reasonable and necessary maintenance.

The following items are not covered by this warranty:

Engine accessories, such as fuel tanks, clutches, transmissions, power drive assemblies, and batteries, unless supplied or installed by Kohler Co. These are subject to the warranties, if any, of their manufacturers.

WE SHALL NOT BE LIABLE FOR SPECIAL, INDIRECT, INCIDENTAL, OR CONSEQUENTIAL DAMAGES OF ANY KIND, including but not limited to labor costs or transportation charges in connection with the replacement or repair of defective parts.

ANY IMPLIED OR STATUTORY WARRANTIES, INCLUDING WARRANTY OF MERCHANTABILITY OR FITNESS FOR A PARTICULAR PURPOSE, ARE EXPRESSLY LIMITED TO THE DURATION OF THIS WRITTEN WARRANTY. We make no other express warranty, nor is anyone authorized to make any in our behalf.

Some states do not allow limitations on how long an implied warranty lasts, or the exclusion or limitation of incidental or consequential damages, so the above limitation or exclusion may not apply to you.

This warranty gives you specific legal rights, and you may also have other rights which vary from state to state.

#### TO OBTAIN WARRANTY SERVICE:

Purchaser must bring the engine to an authorized Kohler service facility. For the facility nearest you, consult your Yellow Pages or write Kohler Co., Attn: Engine Warranty Service Dept., Kohler, Wisconsin, 53044.

ENGINE DIVISION, KOHLER CO., KOHLER, WISCONSIN 53044

FORM NO.: TP-2107-C
ISSUED: 4/87
REVISED: 11/02
MAILED:

LITHO IN U.S.A.



