

# 6.5 HP INTEK™ EDGE

Model Series 121600

# 6.5 HP INTEK™ PRO

Model Series 122600

Displacement 11.5 cu. in. (189 cc)

Bore 2.69 in. (68.3 mm)

Stroke 2.04 in. (51.8 mm)

Oil Capacity 22 fl. oz. (0.65 l)



## Features:

- Dura-Bore™ cast iron cylinder sleeve for extended life
- One-Start™ float carburetor assures consistent one-pull starts
- Large rewind starter reduces pulling effort for easy starts
- Maintenance-free Magnetron® electronic ignition for quick, dependable starts
- Mechanical torque control for additional power
- Composite camshaft and aluminized Lo-Tone muffler for quiet operation
- Dual-Clean™ air cleaner pleated paper filter with a foam pre-cleaner ensures maximum protection for extended engine life
- Overhead valve design (OHV) for cooler operation and longer valve life
- Buyer protection package provides two-year consumer engine warranty

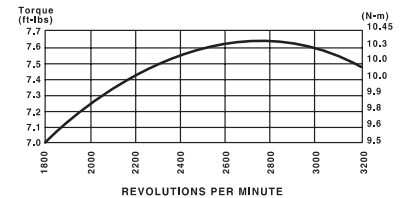
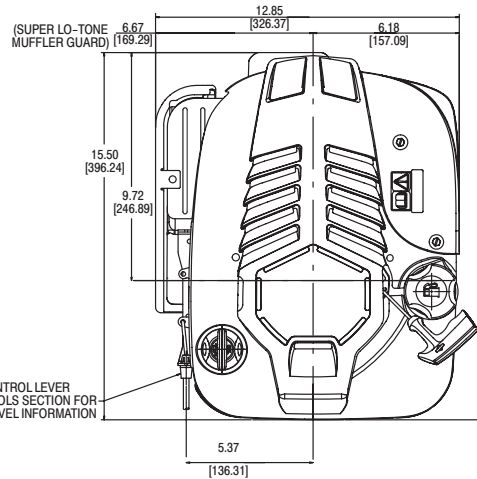
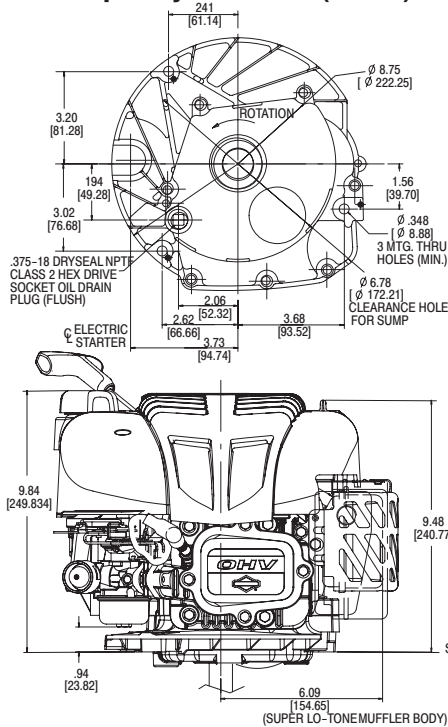

Model Type	Shipping Weight	Crankshaft	Crankshaft (P.T.O.) Extension	Dimension	Starter Position	Ext. Starter Rope	Governor	Controls	Primer Carburetor	Heavy Flywheel	Oil Pump w/Filter	Fuel Tank (Quarts)	Top Governor Speed	Notes
<b>121602</b>														
0505	35	691457	Tapped 3/8-24, 2 WK & Keyway, 7/8" dia.	3-5/32(b)	6	X	M	R/MF	X	X		1.6	3100	
0515	33	691457	Tapped 3/8-24, 2 WK & Keyway, 7/8" dia.	3-5/32(b)	6	X	M	R/MF	X			1.6	3100	▼
0521	30	693291	Tapped 3/8-24, 2 WK & Keyway, 7/8" dia.	2-7/16(b)	6	X	M	R/MF	X			1.6	3100	▼
0522	29	692823	Tapped 3/8-24, WK & Keyway, 7/8" dia.	1-13/16(b)	6	X	M	R/MF	X			1.6	3100	▼
0525	33	691456	Tapped 3/8-24, 2 WK & Keyway, 25mm dia.	3-5/32(b)	6	X	M	R/MF	X			1.6	3100	▼
0526	34	694491	Tapped 3/8-24, 2 WK & Keyway, 25mm dia.	2-7/16 (b)	6	X	M	R/MF	X			1.6	3100	▼
0527		691456	Tapped 3/8-24, 2 WK & Keyway, 25mm dia.	3-5/32(b)	6	X	M	R/MF	X			1.6	3250	▼
<b>121607</b>														
0660	32	691457	Tapped 3/8-24, 2 WK & Keyway, 7/8" dia.	3-5/32(b)	6	X	M	R/MF	X			1.6	3100	▼■
0562	37	691457	Tapped 3/8-24, 2 WK & Keyway, 7/8" dia.	3-5/32(b)	6		M	R/MF	X	X		1.6	3100	■
<b>121612</b>														
0545	36	692803	Tapered Tapped 5/16-24		6		M	FC		X		1.6	3800	
<b>121682</b>														
0550	34	691457	Tapped 3/8-24, 2 WK & Keyway, 7/8" dia. Aux. P.T.O. 1/2" dia. CW	3-5/32(b)	6	X	M	R/MF	X			1.6	3100	▼
0551	34	691457	Tapped 3/8-24, 2 WK & Keyway, 7/8" dia. Aux. P.T.O. 1/2" dia. CCW	3-5/32(b)	6	X	M	R/MF	X			1.6	3100	▼
<b>122672</b>														
0020	36	691457	Tapped 3/8-24, 2 WK & Keyway, 7/8" dia.	3-5/32(b)	6	X	M	R/MF	X		X	1.6	3100	▼

▼ The features on this engine are designed to meet Section 1205.5 of the Consumer Product Safety Commission Safety Standards.

■ Engine equipped with 12 Volt Gear Drive Starter and .5 Amp DC Alternator.