

6.75 Gross Torque 190 CC

Bore 2.69 in. (68.3 mm)
Stroke 2.04 in. (51.8 mm)
Oil Capacity 18-20 fl. oz. (0.53 - 0.59 L)



Features:

- Large rewind starter reduces pulling effort for easy starts
- Maintenance-free Magnatron® electronic ignition for quick, dependable starts
- Mechanical compression release for smooth, quick starting
- Maxi-Clean™ automotive-type pleated paper air filter provides superior protection for long engine life
- Mechanical torque control for additional power
- Composite camshaft and aluminized Lo-Tone™ muffler for low noise operation
- One-Start float carburetor assures consistent one-pull starts
- Buyer protection package provides two-year consumer engine warranty

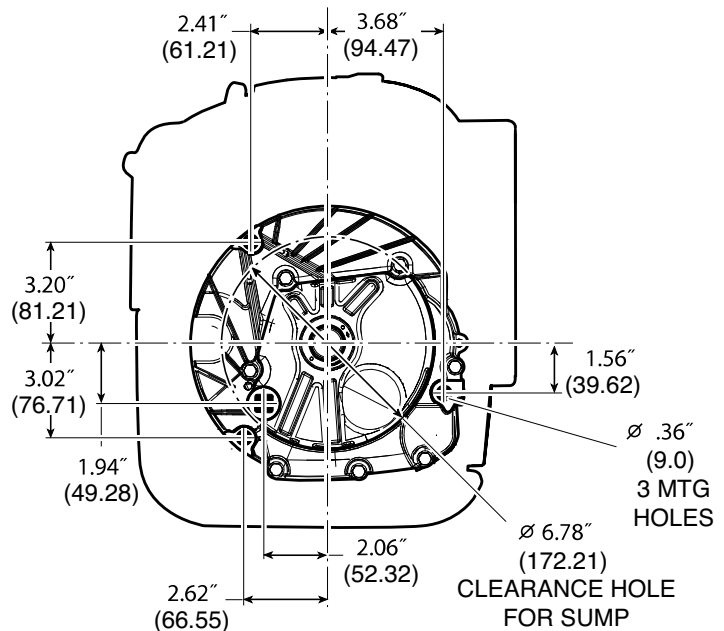
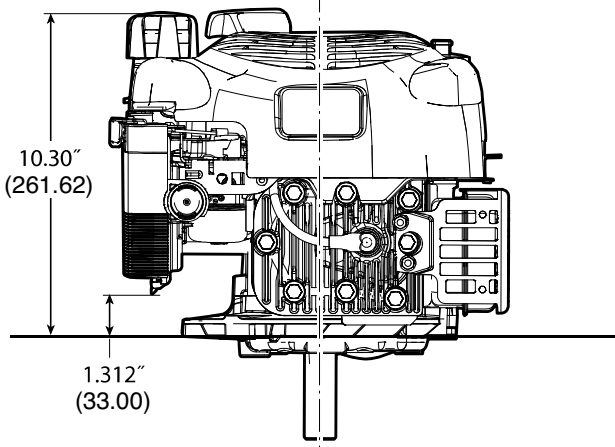
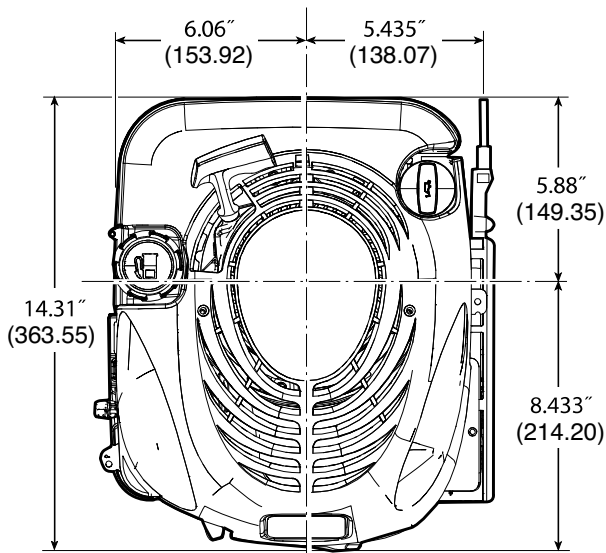

6.75 Gross Torque 190 CC

Model Type	Shipping Weight	Crankshaft	Crankshaft (P.T.O.) Extension	Dimension	Starter Position	Heavy Flywheel	Ext. Starter Rope	Governor	Controls	Fuel Tank (Quarts)	Primer Carburetor	5 Position Choke	Ready Start	High Debris Air Inlet	Top Governor Speed	Notes
126L02																
1002	33	694850	Tapped 3/8-24, 2 WK & Keyway, 7/8" dia	3-5/32(b)	6	X		M	MF	1.6		X			3100	
1003	33	694850	Tapped 3/8-24, 2 WK & Keyway, 7/8" dia.	3-5/32(b)	6	X	X	M	MF	1.6	X				3100	
1004	32	691451	Tapped 3/8-24, 2 WK & Keyway, 7/8" dia.	3-5/32(b)	6	X		M	MF	1.6		X			3100	
1005	32	797372	Tapped 3/8-24, WK & Keyway, 7/8" dia.	1-13/16(b)	6	X	X	M	MF	1.6		X			3700	
1009		691452	Tapped 3/8-24, WK & Keyway, 7/8" dia.	2-7/16(b)	6		X	M	R/MF	1.6			X	X	3100	▼
1010	33	691451	Tapped 3/8-24, 2 WK & Keyway, 7/8" dia.	3-5/32(b)	6	X	X	M	R	1.6	X			X	3600	
1011	29	691451	Tapped 3/8-24, 2 WK & Keyway, 7/8" dia.	3-5/32(b)	6		X	M	R/MF	1.6	X			X	3600	▼
1014		797372	Tapped 3/8-24, 2 WK & Keyway, 7/8" dia.	1-13/16(b)	6	X	X	M	R/MF	1.6			X		3700	
1015	29	691451	Tapped 3/8-24, 2 WK & Keyway, 7/8" dia.	3-5/32(b)	6		X	M	R/MF	1.6	X				3100	▼
1016	28	691452	Tapped 3/8-24, WK & Keyway, 7/8" dia.	2-7/16(b)	6		X	M	R/MF	1.6	X				3100	▼
1018	29	691455	Tapped 3/8-24, WK & Keyway, 7/8" dia.	1-13/16(b)	6		X	M	R/MF	1.6	X				3100	▼
1025	29	691450	Tapped 3/8-24, 2 WK & Keyway, 25mm dia.	3-5/32(b)	6		X	M	R/MF	1.6	X				3100	▼
1026	28	691454	Tapped 3/8-24, 2 WK & Keyway, 25mm dia.	2-7/16(b)	6		X	M	R/MF	1.6	X				3100	▼
1030	30	791061	Tapped 7/16-20, Stepped, WK, 7/8" dia.	1-5/32(b)	6	X	X	M	FC	1.6			X		3100	*
1031	29	696009	Tapped 7/16-20, Keyway, 25mm dia.	3-5/32(b)	6		X	M	R/MF	1.6			X		3100	▼
1615	29	691451	Tapped 3/8-24, 2 WK & Keyway, 7/8" dia.	3-5/32(b)	5		X	M	MF	1.6			X		3100	▼
1625	30	691450	Tapped 3/8-24, 2 WK & Keyway, 25mm dia.	3-5/32(b)	5		X	M	MF	1.6			X		3100	▼
1701	28	694079	Tapped 7/16-20, 25mm Taper	3-5/16(b)	6			M	MF	1.6	X				3100	▼
126L07																
1050	33	691451	Tapped 3/8-24, 2 WK & Keyway, 7/8" dia.	3-5/32(b)	6		X	M	R/MF	1.6	X			X	3600	
1060	38	691451	Tapped 3/8-24, 2 WK & Keyway, 7/8" dia.	3-5/32(b)	6		X	M	R/MF	1.6	X				3100	▼■
1062	38	691450	Tapped 3/8-24, 2 WK & Keyway, 25mm dia.	3-5/32(b)	6		X	M	R/MF	1.6	X				3100	▼■
1660	33	691451	Tapped 3/8-24, 2 WK & Keyway, 7/8" dia.	3-5/32(b)	5		X	M	MF	1.6			X		3100	▼■
1662	33	691450	Tapped 3/8-24, 2 WK & Keyway, 25mm dia.	3-5/32(b)	5		X	M	MF	1.6			X		3100	▼■
126L12																
1006	33	691455	Tapped 3/8-24, WK & Keyway, 7/8" dia.	1-13/16(b)	6	X		M	R/MF	1.6		X			3600	
1007	27	691452	Tapped 3/8-24, WK & Keyway, 7/8" dia.	2-7/16(b)	12	X		M	MF	1.6		X			3600	

▼ The features on this engine are designed to meet Section 1205.5 of the Consumer Product Safety Commission Safety Standards.

■ Engine equipped with 12 Volt Gear Drive Starter and .5 Amp DC Alternator. * BBC Crank Shaft