

5.5 HP QUANTUM® *Diamond Plus*® Model Series 129800

Displacement 11.57 cu. in. (190 cc)

Bore 2.69 in. (68.0 mm)

Stroke 2.04 in. (51.8 mm)

Oil Capacity 20 fl. oz. (0.59 l)



Features:

- Dura-Bore™ cast iron cylinder sleeve for extended life
- Large rewind starter reduces pulling effort for easy starts
- Maintenance-free Magnetron® electronic ignition for quick, dependable starts
- Mechanical compression release for smooth, quick starting
- Maxi-Clean™ automotive-type pleated paper air filter provides superior protection for long engine life
- Mechanical torque control for additional power
- Composite camshaft and aluminized Lo-Tone muffler for low noise operation
- One-Start™ float carburetor assures consistent one-pull starts
- Buyer protection package provides two-year consumer engine warranty and one-year commercial engine warranty

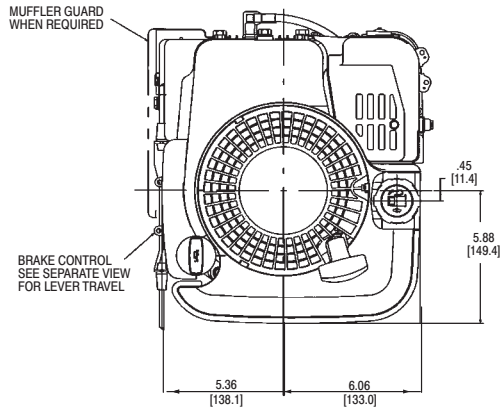
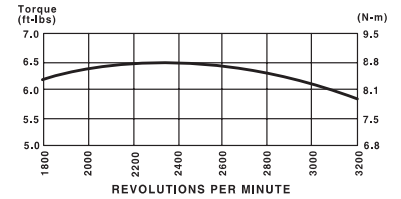
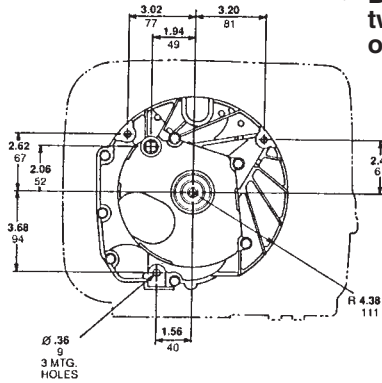
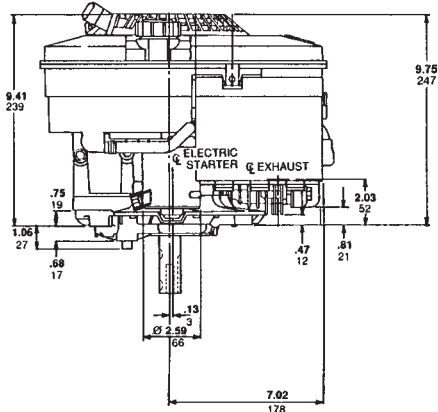

Model Type	Shipping Weight	Crankshaft	Crankshaft (P.T.O.) Extension	Dimension	Starter Position Changeable	Ext. Starter Rope	Governor	Controls	Primer Carburetor	Heavy Flywheel	Fuel Tank (Quarts)	Top Governor Speed	Notes
129802													
2915	28	691451	Tapped 3/8-24, 2 WK & Keyway, 7/8" dia.	3-5/32(b)	6	X	M	R/MF	X	1.6	3100		▼
2925	28	691450	Tapped 3/8-24, 2 WK & Keyway, 25 mm dia.	3-5/32(b)	6	X	M	R/MF	X	1.6	3100		▼
129807													
2960	33	691451	Tapped 3/8-24, 2 WK & Keyway, 7/8" dia.	3-5/32(b)	6	X	M	R/MF	X	1.6	3100		▼■
129882													
2950	31	691451	Tapped 3/8-24, 2 WK & Keyway, 7/8" dia., Aux. P.T.O. 1/2 dia., CW	3-5/32(b)	6	X	M	R/MF	X	1.6	3200		▼
2951	29	691451	Tapped 3/8-24, 2 WK & Keyway, 7/8" dia., Aux. P.T.O. 1/2 dia., CCW	3-5/32(b)	6	X	M	R/MF	X	1.6	3200		▼

▼ The features on this engine are designed to meet Section 1205.5 of the Consumer Product Safety Commission Safety Standards.
■ Engine equipped with 12 Volt Gear Drive Starter and .5 Amp DC Alternator.