

SNOW SERIES

9.00 Gross Torque

205 CC

Bore 2.69 in. (68.3 mm)
 Stroke 2.2 in. (55.9 mm)
 Oil Capacity 18-20 fl. oz. (0.54 - 0.59 L)



Features:

- Kool Bore™ aluminum alloy bore for cooler operation
- Maintenance-free Magnetron® electronic ignition for quick, dependable starts
- Overhead valve design (OHV) for cooler operation and longer valve life
- Freeze-resistant recoil starter with oversized mitt-grip rewind handle
- Easy-start primer is easy-to-find and use for fast, reliable cold weather starting
- Buyer protection package provides two-year consumer engine warranty

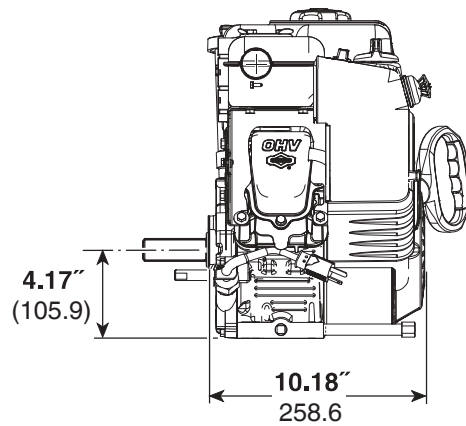
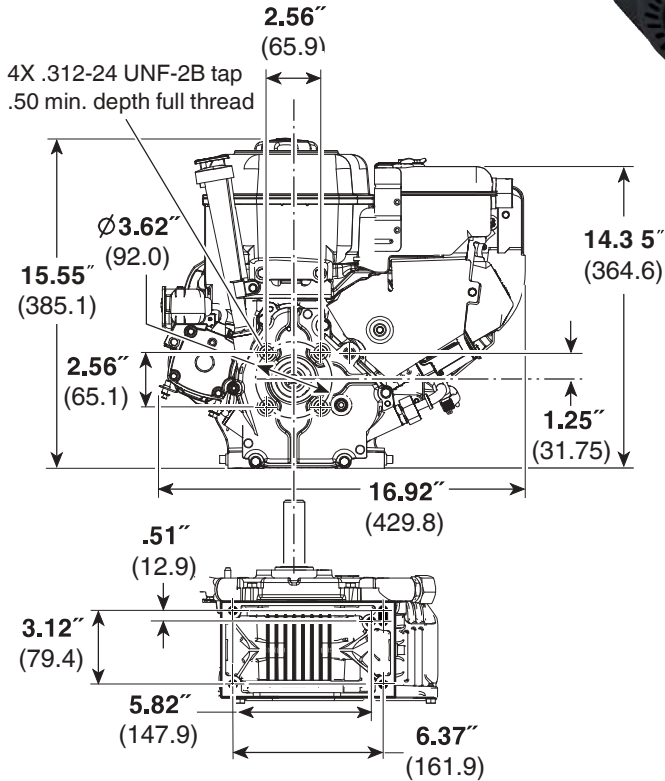

Model Type	Shipping Weight	Crankshaft	Crankshaft (P.T.O.) Extension	Dimension	Starter Position	Oil Filler & Drain	Governor	Controls	Manual Choke	Fuel Tank (Quarts)	Key Switch Stop	Flange Mtg.	Top Governor Speed	Notes
12D112														
0007	39	699445	3/4" dia., Keyway, tapped 5/16-24	2-27/64(c)	3	T	M	MF/R	X	3.2	X	X	3600	■
0008		699454	3/4" dia., Keyway, tapped 3/8-24	2-9/16(c)	3	T	M	MF	X	3.2	X	X	3600	■
0009	40	699451	1" dia., Keyway, tapped 5/16-24	2-27/64(c)	3	T	M	MF/R	X	3.2	X	X	3600	■
12D113														
0017	49	699445	3/4" dia., Keyway, tapped 5/16-24	2-27/64(c)	3	T	M	R/AG/MF	X	3.2	X	X	3600	□
0019	49	699451	1" dia., Keyway, tapped 5/16-24	2-27/64(c)	3	T	M	R/AG/MF	X	3.2	X	X	3600	□
12D132														
0036		816538	3/4" dia., Keyway, tapped 5/16-24	2-27/64(c)	3	T	M	MF/R	X	3.2	X	X	3600	■
12D193														
0018	44	699445	3/4" dia., Keyway, tapped 5/16-24, 5/16-24 Aux. P.T.O. 1/2 dia.	2-27/64(c)	3	T	M	R/AG/MF	X	3.2			3600	□

□ 110 Volt Gear Drive Starter ■ Engine equipped to receive 110 Volt Starter