

Vanguard® 6.5 Gross HP

203 cc

Bore 2.68 in. (68.07 mm)

Stroke 2.21 in. (56.13 mm)

Oil Capacity 20 fl. oz. (0.59 L)

FEATURES:

Cyclonic air filter with 120% more dust holding capacity and 3x the filter life

TransportGuard® Single fuel/ignition shut off system protects the engine from oil/fuel dilution during transport

Commercial-style carburetor includes nickel plating to resist stale fuel deposit buildup

CDI ignition with variable timing to optimize speed and torque

Mechanical Governor

Buyer protection package provides three-year commercial limited warranty

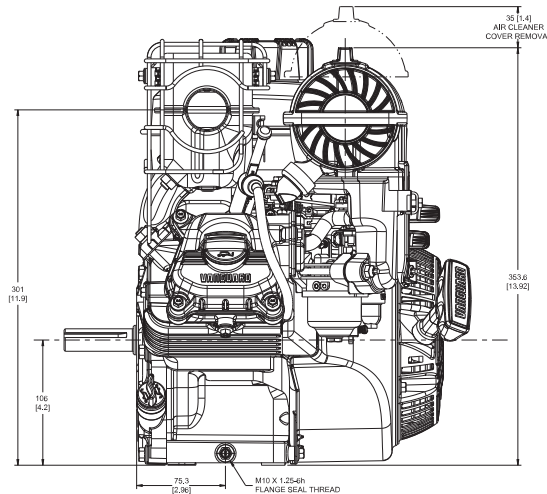
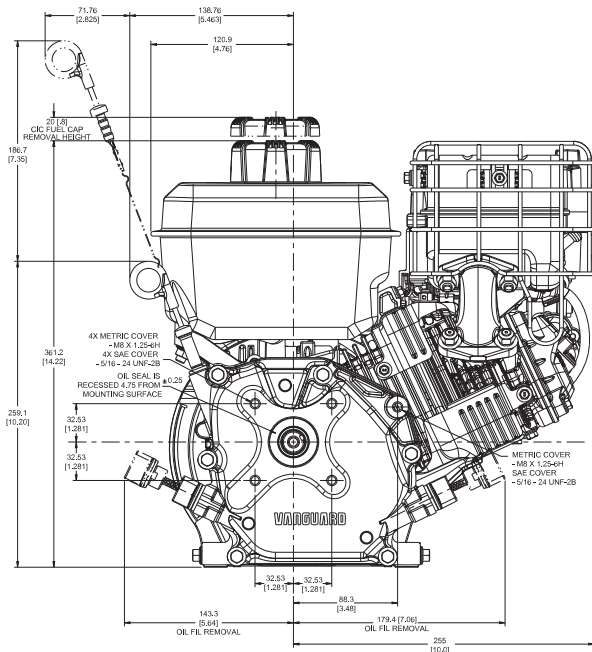

†All power levels are stated gross horsepower at 3600 RPM per SAE J1940 as rated by Briggs & Stratton.

MTT	Crankshaft #	P.T.O. Diameter	Drilled & Tapped	Keyway	Length	Starter Position	Controls	Manual Choke	Flange Mitg.	Oil Sensor	Fuel Tank (Qt.)	Panel Control	Alternator	Governed Speed	Notes
12V332															
0014-F1	596975	1 in.	3/8-24	1/4-Sq	2-7/8	10:00	MF/R	Yes	Yes	Yes	3.2			3600	
0013-F1	596958	3/4 in.	5/16-24	3/16-Sq	2-27/64	10:00	MF/R	Yes	Yes	Yes	3.2			3600	P
12V352															
0015-F1	596973	3/4 in.	6:1 CCW	3/16-Sq	1-13/16	10:00	MF/R	Yes	Yes	Yes	3.2			3600	P
12V337															
0139-F1	596958	3/4 in.	5/16-24	3/16-Sq	2-27/64	10:00	MF/R	Yes	Yes	Yes	3.2		20A,DC	3600	1

(1) 12 Volt Gear Drive Starter