

# INTEK™ SNOW 9.0 Gross HP

## 305 CC

Bore 3.12 in. (79.0 mm)

Stroke 2.43 in. (61.0 mm)

Oil Capacity 26-28 fl. oz. (0.77 - 0.83 L)



### Features:

- Kool Bore™ Aluminum alloy bore for cooler operation
- Maintenance-free Magnetron® electronic ignition for quick, dependable starts
- Overhead valve design (OHV) for cooler operation and longer valve life
- Freeze-resistant recoil starter with oversized mitt-grip rewind handle
- Easy-start primer is easy-to-find and use for fast, reliable cold weather starting

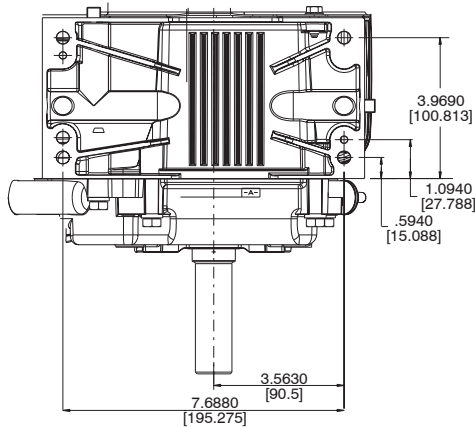
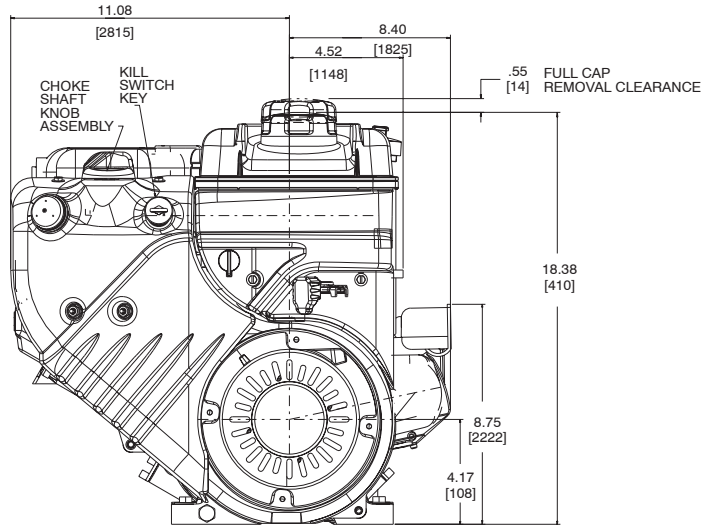
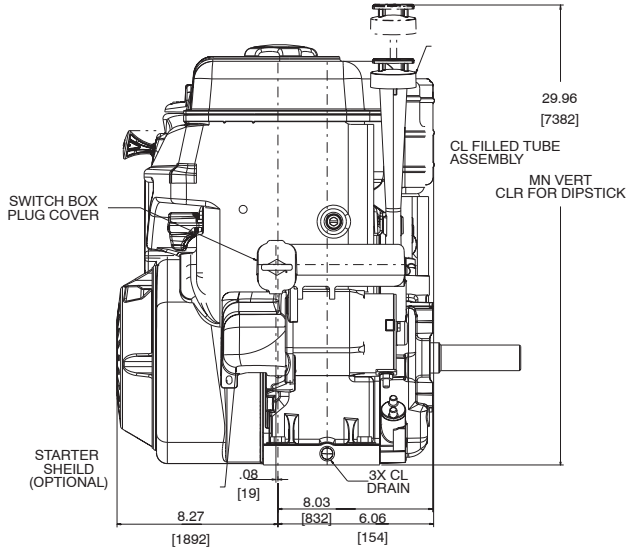

Model Type	Shipping Weight	Crankshaft	Crankshaft (P.T.O.) Extension	Dimension	Starter Position	Oil Filler & Drain	Governor	Controls	Manual Choke	Fuel Tank (Quarts)	Key Switch Stop	Flange Mtg.	Top Governor Speed	Notes
20A412														
0007	67	695462	1" dia., Keyway, tapped 7/16-20	3-21/32(c)	3	D	M	MF/R	X	4	X	X	3600	•
0009	66	695369	1" dia., Keyway, tapped 3/8-24	2-29/32(c)	3	D	M	MF/R	X	4	X	X	3600	•

• Equipped to Receive 110 Volt Gear Drive Starter