

14.50 Gross Torque 305 CC

Bore 3.12 in. (79.2 mm)

Stroke 2.44 in. (61.9 mm)

Oil Capacity 26-28 fl. oz. (0.77 - 0.83 L)

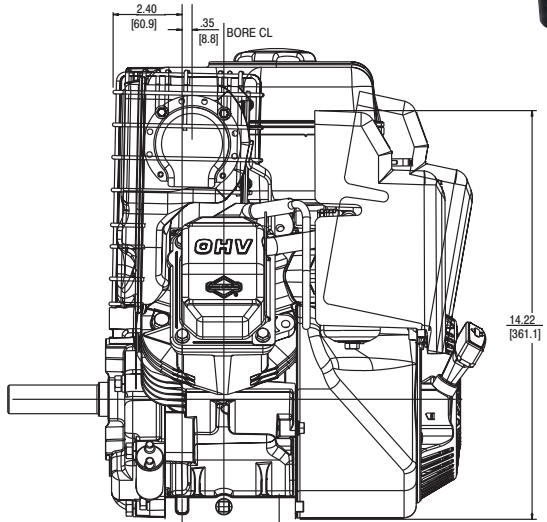

4X .375-16 UNC-2B
.562 MIN. [14.33] FULL THREAD
.875 MIN. [22.23] DRILL DEPTH

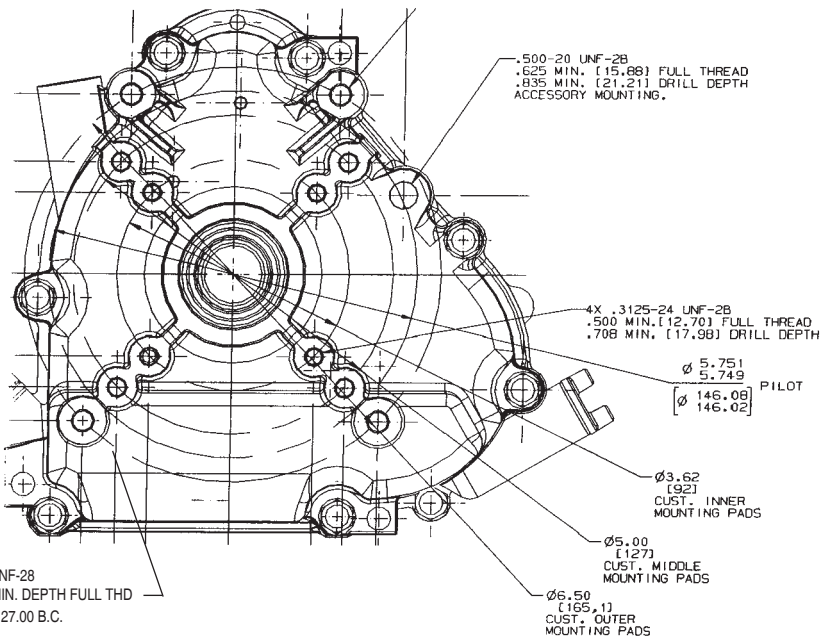
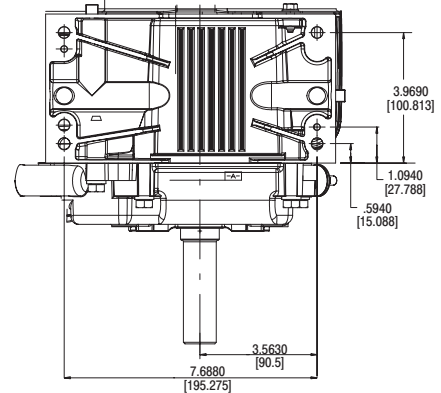

4X .312-24 UNF-28
.750 19.05 MIN. DEPTH FULL THD
ON Ø5.000 127.00 B.C.

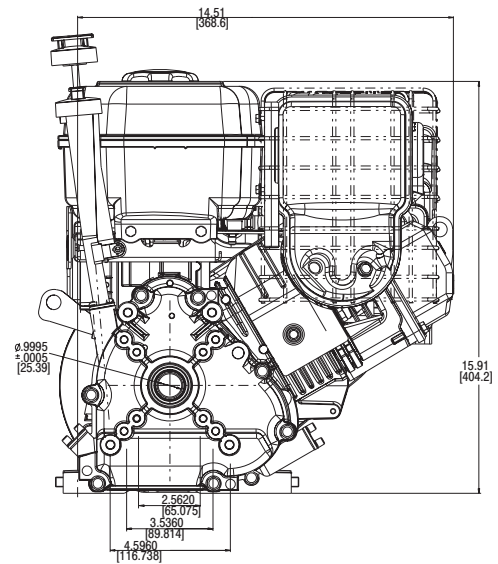

- Kool Bore™ aluminum alloy bore for cooler operation
- Maintenance-free Magnetron® electronic ignition for quick, dependable starts
- Overhead valve design (OHV) for cooler operation and longer valve life
- Maxi-Clean™ automotive-type pleated paper air filter provides superior protection for long engine life
- Buyer protection package provides two-year consumer engine warranty

To make the center line of crankshaft the same as 190000 and 250000 Model Series, order 695154 spacer kit.

Model Type	Shipping Weight	Crankshaft	Crankshaft (P.T.O.) Extension	Dimension	Starter Position Bolt-On/Changeable	Governor	Controls	Flange Mfg.	Manual Choke	Remote Stop Switch	Fuel Tank (Quarts)	Top Governor Speed	Notes
20T232													
0036	52	794717	1" dia., Keyway, tapped 7/16-20	3-21/32(c)	10:30	M	AG/R/MF	X	X	X	4	3600	•

• Ball bearing PTO