

# Power Built™ 10.5 Gross HP 344 CC

Bore 3.44 in. (87.3 mm)  
Stroke 2.26 in. (57.5 mm)  
Oil Capacity 48 fl. oz. (1.4 L)



## Features:

- Dura-Bore™ cast iron cylinder sleeve for extended life
- Float carburetor for consistent easy starting
- Maintenance-free Magnetron® electronic ignition for quick, dependable starts
- Maxi-Clean™ automotive type pleated paper air filter provides superior protection for long engine life
- Overhead valve design (OHV) for cooler operation and longer valve life
- Buyer protection package provides two-year consumer engine warranty

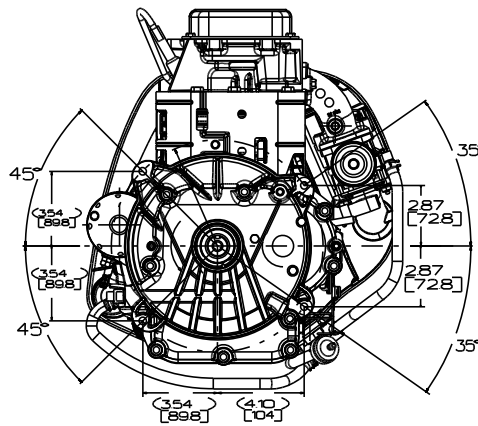
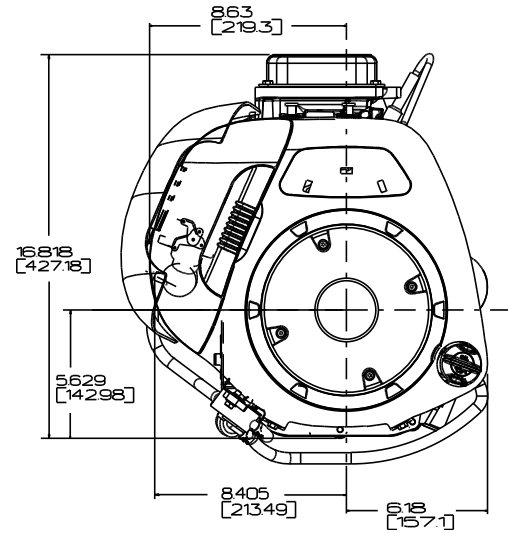
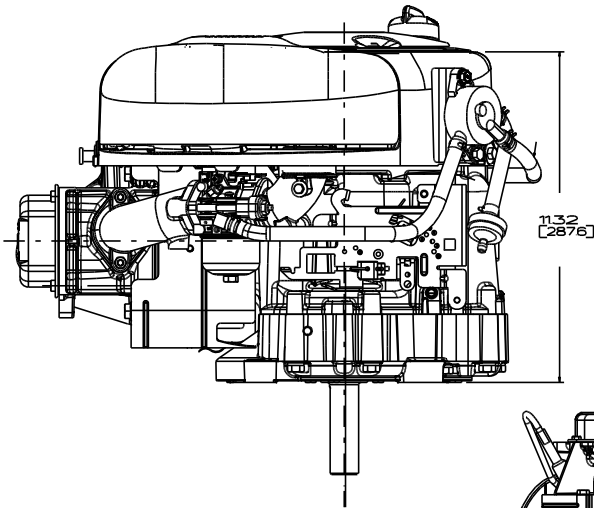

| Model Type    | Shipping Weight | Crankshaft | Crankshaft (P.T.O.) Extension   | Dimension | Starter Position Bolt-On/Changeable | Ext. Oil Fill & Dipstick | Governor | Controls | Pulse Fuel Pump | Choke-A-matic® | Ground Wire Terminal | Fuel Tank (Quarts) | Top Governor Speed | Notes |
|---------------|-----------------|------------|---------------------------------|-----------|-------------------------------------|--------------------------|----------|----------|-----------------|----------------|----------------------|--------------------|--------------------|-------|
| <b>215802</b> |                 |            |                                 |           |                                     |                          |          |          |                 |                |                      |                    |                    |       |
| 0015          | 65              | 698382     | Tapped 7/16-20, Keyway, 1" dia. | 3-5/32(b) | 9                                   | X                        | M        | R        |                 | X              | X                    | ■                  | 3400               |       |
| <b>215807</b> |                 |            |                                 |           |                                     |                          |          |          |                 |                |                      |                    |                    |       |
| 0025          | 72              | 698382     | Tapped 7/16-20, Keyway, 1" dia. | 3-5/32(b) | 9                                   | X                        | M        | R        | X               | X              | X                    | ■                  | 3600               | ▼     |
| 0026          | 72              | 698382     | Tapped 7/16-20, Keyway, 1" dia. | 3-5/32(b) |                                     | X                        | M        | R        | X               | X              | X                    | ■                  | 3600               | ▼     |

■ Fuel tank omitted. ▼ Engine equipped with 12 Volt Gear Drive Starter and Dual Circuit Alternator. (3 Amp DC - 14 Volts AC)