

INTEK™ 11.5 Gross HP 344 CC

Bore 3.44 in. (87.3 mm)
Stroke 2.26 in. (57.5 mm)
Oil Capacity 48 fl. oz. (1.4 L)



Features:

- Dura-Bore™ cast iron cylinder sleeve for extended life
- Float carburetor for consistent easy starting
- Maintenance-free Magnetron® electronic ignition for quick, dependable starts
- Dual-Clean™ air cleaner pleated paper filter with a foam pre-cleaner ensures maximum protection for extended engine life
- Overhead valve design (OHV) for cooler operation and longer valve life
- Patented linear balancing system provides smoother performance
- Buyer protection package provides two-year consumer engine warranty

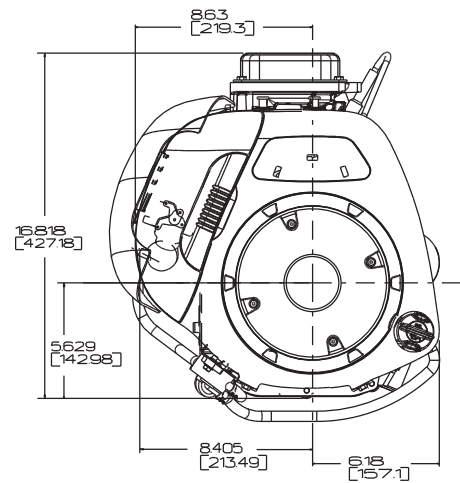
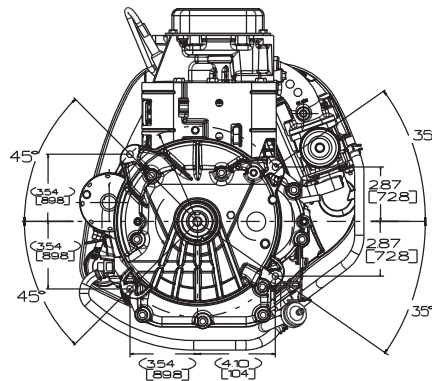
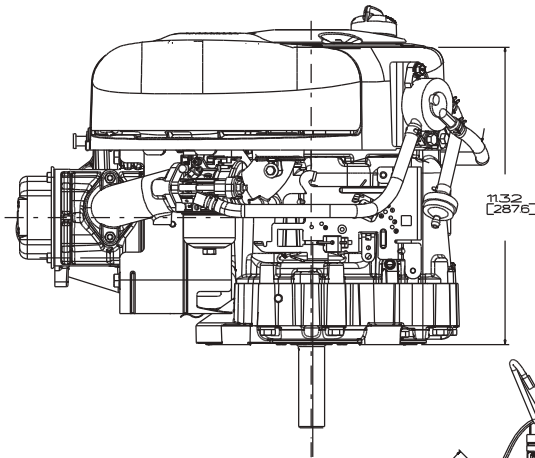

For Fuel Tank Dimensions, see page 50

Model Type	Shipping Weight	Crankshaft	Crankshaft (P.T.O.) Extension	Dimension	Starter Position Bolt-On/Changeable	Ext. Oil Fill & Dipstick	Governor	Controls	Pulse Fuel Pump	Remote Choke	Choke-A-Matic®	Ground Wire Terminal	Fuel Tank (Quarts)	Top Governor Speed	Notes
217902															
3015	72	697390	Tapped 7/16-20, Keyway, 1" dia.	3-5/32(b)	9	X	M	R			X	X	■	3400	
4020	72	697390	Tapped 7/16-20, Keyway, 1" dia.	3-5/32(b)	9	X	M	R	X		X	X	2.8	3400	
217907															
3019	77	697390	Tapped 7/16-20, Keyway, 1" dia.	3-5/32(b)	9	X	M	R			X	X	■	3600	▼
3025	77	697390	Tapped 7/16-20, Keyway, 1" dia.	3-5/32(b)		X	M	R			X	X	■	3600	▼
4028	77	697390	Tapped 7/16-20, Keyway, 1" dia.	3-5/32(b)		X	M	R	X		X	X	2.8	3600	▼

■ Fuel tank omitted. ▼ Engine equipped with 12 Volt Gear Drive Starter and Dual Circuit Alternator. (3 Amp DC - 14 Volts AC)