

# Vanguard™ 16.0 Gross HP 480 CC

Bore 2.68 in. (68 mm)  
Stroke 2.60 in. (66 mm)  
Oil Capacity 48 fl. oz. (1.4



## Features:

- Dura-Bore™ cast iron cylinder sleeve for extended life
- Dependable float feed type carburetor with integral fuel pump for remote mount fuel tank
- Maintenance-free Magnetron® electronic ignition for quick, dependable starts
- Dual-Clean™ air cleaner pleated paper filter with a foam pre-cleaner ensures maximum protection for extended engine life
- Full pressure lubrication with spin-on oil filter assures controlled lubrication for extended component life
- Overhead valve design (OHV) for cooler operation and longer valve life
- Buyer protection package provides two-year commercial engine warranty

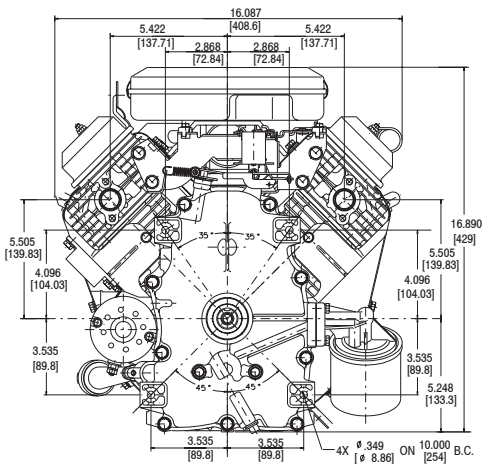
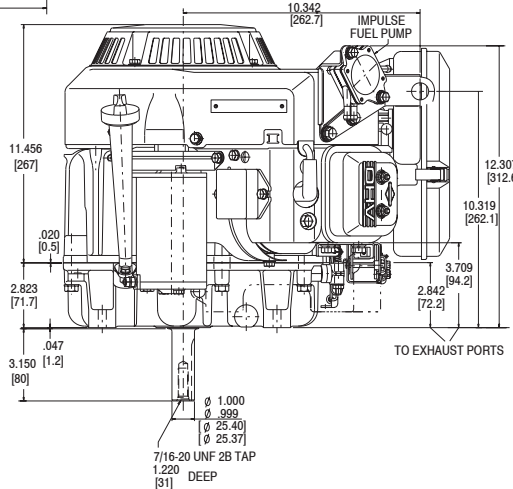
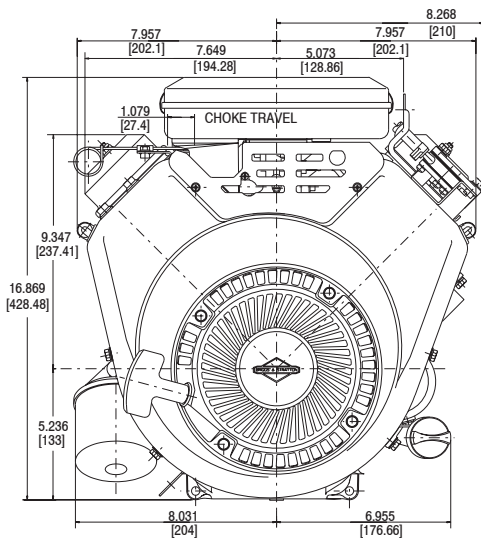

Model Type	Shipping Weight	Crankshaft	Crankshaft (P.T.O.) Extension	Dimension	Starter Position Bolt-On/Changeable	Governor	Controls	Exhaust System	Fuel Tank (Quarts)	Ground Wire Terminal	Ext. Oil Fill & Dipstick	Oil Pump w/Filter	Remote Choke	Top Governor Speed	Notes
305772															
0020	81	692159	Tapped 7/16-20, Keyway, 1" dia.	3-5/32(b)	9	M	R	•	■	X	X	X	X	3600	
305777															
0032	85	692159	Tapped 7/16-20, Keyway, 1" dia.	3-5/32(b)		M	R	•	■	X	X	X	X	3300	†

\* Exhaust manifold and muffler omitted. See Engine Accessories Catalog MS-3880 for Exhaust Manifold and Muffler Options.

■ Fuel tank omitted † Engine equipped with 12 Volt Gear Drive Starter and 16 Amp DC Alternator.