

# Professional Series™

## 17.5 Gross HP

### 500 CC

Bore 3.56 in. (90.5 mm)  
 Stroke 3.06 in. (77.8 mm)  
 Oil Capacity 48 fl. oz. (1.4 L)



### Features:

- Dura-Bore™ cast iron cylinder sleeve for extended life
- Float carburetor for consistent easy starting
- Maintenance-free Magnetron® electronic ignition for quick, dependable starts
- Advanced Debris Management System with a dual seal, cartridge-style air filter provides maximum protection and extends engine life
- Overhead valve design (OHV) for cooler operation and longer valve life
- Patented linear balancing system provides smoother performance
- Premium oil filter
- Platinum spark plugs for extended life
- Buyer protection package provides two-year limited consumer engine warranty

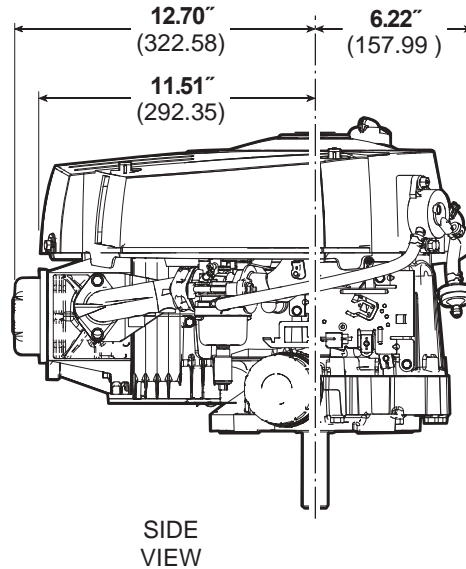
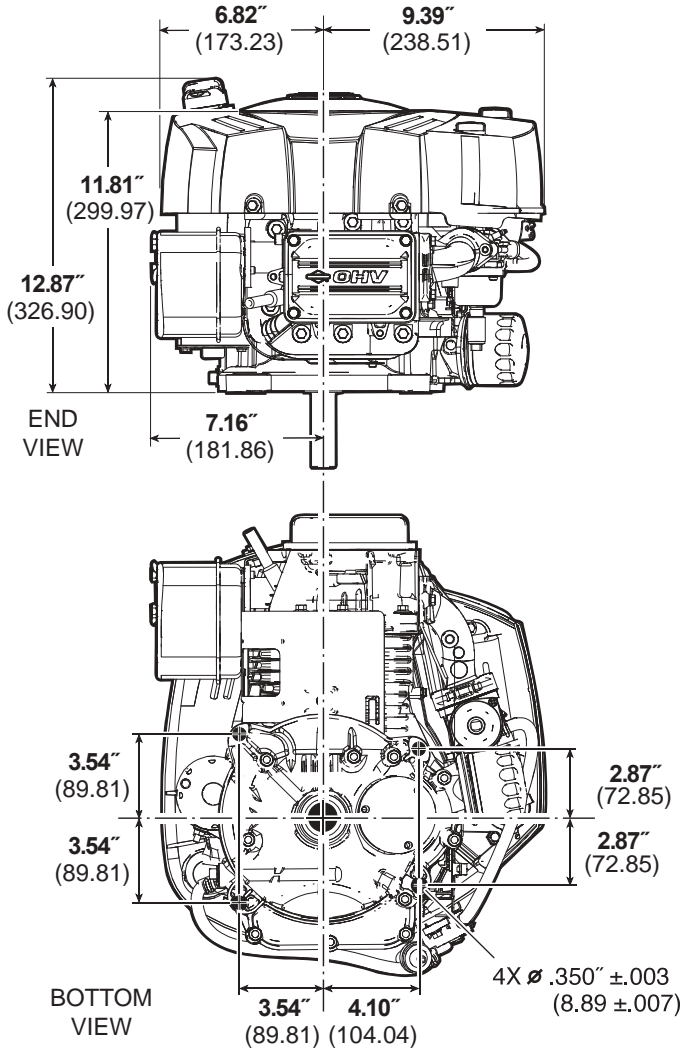

Model Type	Shipping Weight	Crankshaft	Crankshaft (P.T.O.) Extension	Dimension	Starter Position Bolt-On/Changeable	Ext. Oil Fill & Dipstick	Governor	Controls	Pulse Fuel Pump	Oil Pump with Filter	Choke-A-Matic®	Ground Wire Terminal	Fuel Tank (Quarts)	Top Governor Speed	Notes
31L777															
3136	90	697516	Tapped 7/16-20, Keyway, 1" dia.	3-5/32(b)		X	M	R	X	X	X	X	■	3300	▼

■ Fuel tank omitted. ▼ Engine equipped with 12 Volt Gear Drive Starter and 9 Amp DC Alternator.