

18 HP VANGUARD™ Model Series 350400

Displacement 34.75 cu. in. (570 cc)

Bore 2.83 in. (72 mm)

Stroke 2.75 in. (70 mm)

Oil Capacity:

48 fl. oz. (1.42 l) w/o Filter

56 fl. oz. (1.66 l) w/Filter



COMMERCIAL POWER



Features:

- Dura-Bore™ cast iron cylinder sleeve for extended life
- Float carburetor for consistent easy starting
- Maintenance-free Magnetron® electronic ignition for quick, dependable starts
- Dual-Clean™ air cleaner pleated paper filter with a foam pre-cleaner ensures maximum protection for extended engine life
- Full pressure lubrication with spin-on oil filter assures controlled lubrication for extended component life
- Overhead valve design (OHV) for cooler operation and longer valve life
- Buyer protection package provides two-year commercial engine warranty

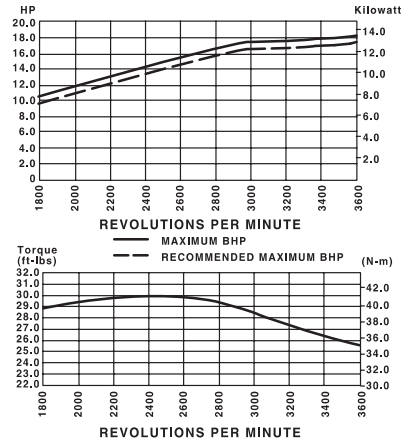
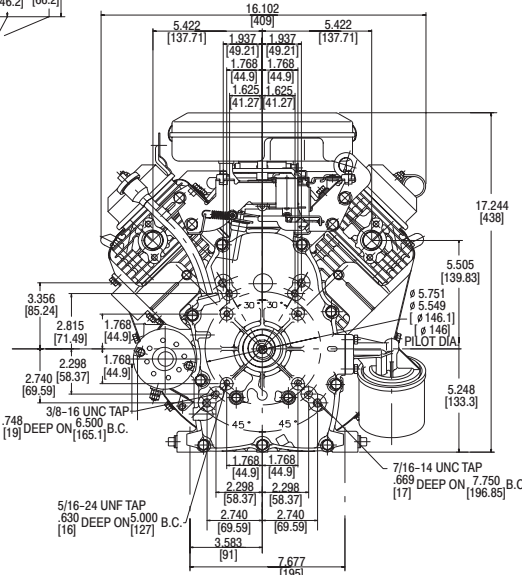
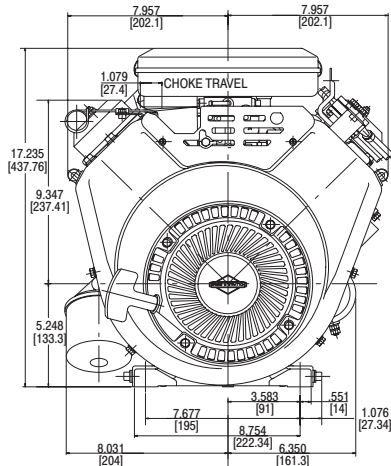
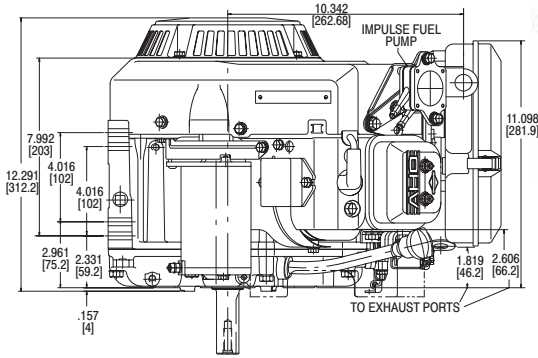

See Engine Accessories & Products Catalog Form MS-3880 for Exhaust Manifold and Muffler Options.

Model Type	Shipping Weight	Crankshaft	Crankshaft (P.T.O.) Extension	Dimension	Starter Position	Bolt-On/Changeable	Oil Filler & Drain	Governor	Controls	Exhaust System	Fuel Tank (Quarts)	Pulse Fuel Pump	Flange Fuel Pump	Oil Pump w/Filter	Manual & Remote Choke	Top Governor Speed	Notes
350442																	
1365	88	692171	1" dia., Keyway, tapped 3/8-24	2-29/32(c)	9	★	M	AG/R/MF	•	9	X	X	X	X	3600		
350447																	
1009	98	692171	1" dia., Keyway, tapped 3/8-24	2-29/32(c)	9	★	E	FC	•	9	X	X	X	X	3600	□	
1079	89	692171	1" dia., Keyway, tapped 3/8-24	2-29/32(c)	9	★	M	AG/R/MF	•	■	X	X	X	X	3600	◆	
1087	90	691139	1-1/8" dia., Keyway, tapped 7/16-20	4(c)	9	★	M	AG/R/MF	•	■	X	X	X	X	3600	◆	
1105	89	692173	Tapered, tapped 5/16-24	3-51/64(c)	9	★	E	FC	•	■	X	X	X		3600	◆	
1366	102	692171	1" dia., Keyway, tapped 3/8-24	2-29/32(c)	9	★	M	AG/R/MF	•	9	X	X	X	X	3600	◆	
1375	93	692171	1" dia., Keyway, tapped 3/8-24	2-29/32(c)	9	★	M	AG/R/MF	•	■	X	X	X	X	3600	◆	
1377	89	692170	Threaded 1-14, 1" thread length	3-21/32(c)	9	★	M	AG/R/MF	•	■	X	X	X	X	3600	◆	
1378	89	692173	Tapered, tapped 5/16-24	3-51/64(c)	9	★	M	AG	•	■	X	X	X		3750	◆	
1396	96	692171	1" dia., Keyway, tapped 3/8-24	2-29/32(c)	9	★	M	AG/R/MF	•	9	X	X	X	X	3600	◆	

★ Oil fill and dipstick in cover; dual drain. ◆ Engine equipped with 12 Volt Gear Drive Starter and 16 Amp DC Alternator with Starter Panel Assembly.
 □ Engine equipped with 12 Volt Gear Drive Starter and 20 Amp DC Alternator with Starter Panel. ■ Fuel tank omitted. • Exhaust manifold and muffler omitted.